

32-Bit RISC Microprocessor TX19 Family

TMP1962F10AXBG

1. Features

The TX19 is a family of high-performance 32-bit microprocessors that offers the speed of a 32-bit RISC solution with the added advantage of a significantly reduced code size of a 16-bit architecture. The instruction set of the TX19 includes as a subset the 32-bit instructions of the TX39, which is based on the MIPS R3000A™ architecture. Additionally, the TX19 supports the MIPS16 Application-Specific Extensions (ASE) for improved code density.

The TMP1962 is built on a TX19 core processor and a selection of intelligent peripherals. The TMP1962 is suitable for low-voltage and low-power applications.

Features of the TMP1962 include the following:

(1) TX19 core processor

- 1) Two instruction set architecture (ISA) modes: 16-bit ISA for code density and 32-bit ISA for speed
 - The 16-bit ISA is object-code compatible with the code-efficient MIPS16 ASE.
 - The 32-bit ISA is object-code compatible with the high-performance TX39 family.

2) High performance combined with low power consumption

— High performance

- Single clock cycle execution for most instructions
- 3-operand computational instructions for high instruction throughput
- 5-stage pipeline
- On-chip high-speed memory
- DSP function: Executes 32-bit x 32-bit multiplier operations in a single clock cycle.

030619EBP

- The information contained herein is subject to change without notice.
- The information contained herein is presented only as a guide for the applications of our products. No responsibility is assumed by TOSHIBA for any infringements of patents or other rights of the third parties which may result from its use. No license is granted by implication or otherwise under any patent or patent rights of TOSHIBA or others.
- TOSHIBA is continually working to improve the quality and reliability of its products. Nevertheless, semiconductor devices in general can malfunction or fail due to their inherent electrical sensitivity and vulnerability to physical stress. It is the responsibility of the buyer, when utilizing TOSHIBA products, to comply with the standards of safety in making a safe design for the entire system, and to avoid situations in which a malfunction or failure of such TOSHIBA products could cause loss of human life, bodily injury or damage to property.
In developing your designs, please ensure that TOSHIBA products are used within specified operating ranges as set forth in the most recent TOSHIBA products specifications. Also, please keep in mind the precautions and conditions set forth in the "Handling Guide for Semiconductor Devices," or "TOSHIBA Semiconductor Reliability Handbook" etc..
- The TOSHIBA products listed in this document are intended for usage in general electronics applications (computer, personal equipment, office equipment, measuring equipment, industrial robotics, domestic appliances, etc.). These TOSHIBA products are neither intended nor warranted for usage in equipment that requires extraordinarily high quality and/or reliability or a malfunction or failure of which may cause loss of human life or bodily injury ("Unintended Usage"). Unintended Usage include atomic energy control instruments, airplane or spaceship instruments, transportation instruments, traffic signal instruments, combustion control instruments, medical instruments, all types of safety devices, etc.. Unintended Usage of TOSHIBA products listed in this document shall be made at the customer's own risk.
- The products described in this document are subject to the foreign exchange and foreign trade laws.
- TOSHIBA products should not be embedded to the downstream products which are prohibited to be produced and sold, under any law and regulations.
- For a discussion of how the reliability of microcontrollers can be predicted, please refer to Section 1.3 of the chapter entitled Quality and Reliability Assurance/Handling Precautions.

- Low power consumption
 - Optimized design using a low-power cell library
 - Programmable standby modes in which processor clocks are stopped
- 3) Fast interrupt response suitable for real-time control
 - Distinct starting locations for each interrupt service routine
 - Automatically generated vectors for each interrupt source
 - Automatic updates of the interrupt mask level
- (2) On-chip ROM/RAM

Product	On-chip ROM	On-chip RAM
TMP1962C10BXBG	1 Mbyte	40 kbyte
TMP1962F10AXBG	1 Mbyte (Flash)	40 Kbyte

Collection function on ROM (8 words x 8 blocks)
- (3) External memory expansion
 - 16-Mbyte off-chip address space for code and data
 - External bus interface with dynamic bus sizing for 8-bit and 16-bit data ports (Separate bus/multiplex bus)
- (4) 8-channel DMA controller
 - Interrupt- or software-triggered
 - DMA transfers between on-chip or external memory and I/O module
- (5) 12-channel 8-bit timer
 - 8-bit/16-bit/24-bit/32-bit interval timer mode
 - 8-bit PWM mode
 - 8-bit PPG mode
- (6) 4-channel 16-bit timer
 - 16-bit interval timer mode
 - 16-bit event counter mode
 - 16-bit PPG output
 - Input capture function
 - 2-channel dual input counter function
- (7) 32-bit input capture
 - 8-channel 32-bit input capture register
 - 8-channel 32-bit compare register
 - 1-channel 32-bit time base timer
- (8) 7-channel general-purpose serial interface
Either UART mode or synchronous transfer mode can be selected.
- (9) 1-channel serial bus interface
Either I²C bus mode or clock-synchronous mode can be selected.
- (10) 24-channel 10-bit A/D converter (with internal sample/hold)

- External trigger start function
- Fixed channel/scan mode
- Single/repeat mode
- Timer monitor function

(11) Watchdog timer

(12) 4-channel chip select/wait controller

(13) Interrupt sources

- 4 CPU interrupts: software interrupt instruction
- 55 internal interrupts: 7 priority levels, with the exception of the watchdog timer interrupt
- 25 external interrupts: 7 priority levels, with the exception of the NMI interrupt
1 used for an interrupt source and 14 used for KWUP

(14) 202-pin input/output ports

(15) Four standby modes

- IDLE (HALT, DOZE), STOP

(16) Clock generator

- On-chip PLL (x3)
- Clock gear: Divides the operating speed of the CPU by 1/2, 1/4 or 1/8

(17) Endian Bi-Endian

Big-endian

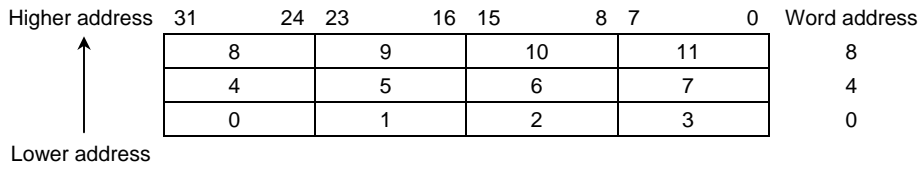

Byte 0 is the most significant byte (MSB) (bits 31-24)

The address of a word data item is the address of its MSB (byte 0).

Little-endian

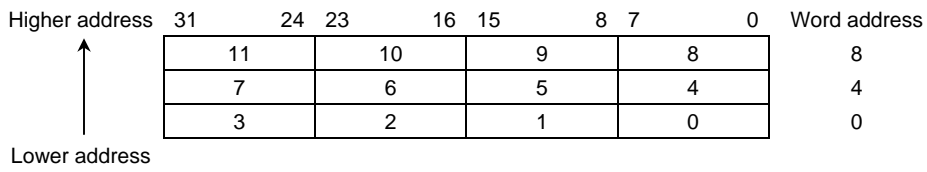

Byte 0 is the least significant byte (LSB) (bits 7-0)

The address of a word data item is the address of its LSB (byte 0).

(18) Operating frequency

40.5 MHz (Vcc = 2.2 V to 2.7 V)

(19) Package

P-FBGA281 (13 x 13 x 0.65 mm pitch)

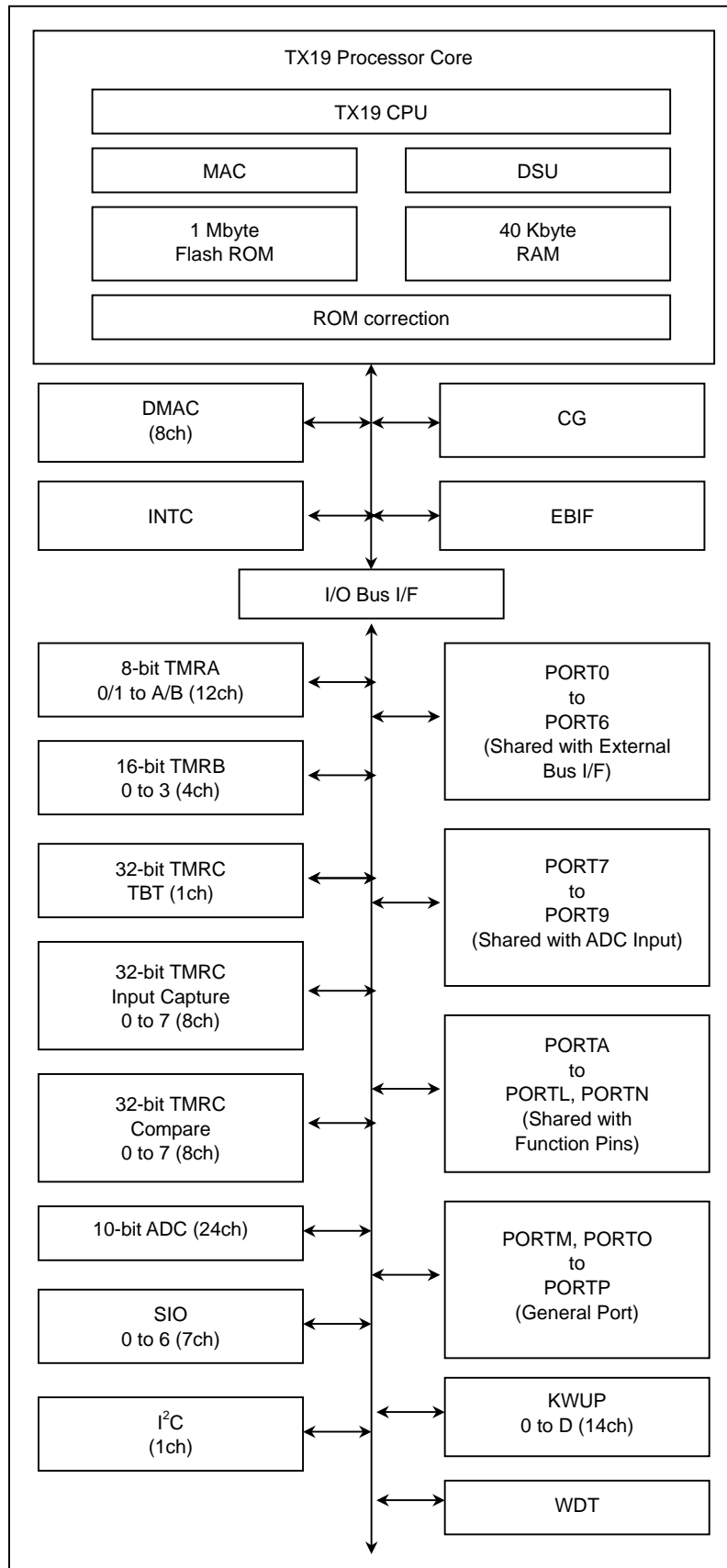

Figure 1.1 TMP1962F10AXBG Block Diagram

2. Pin Assignment

This section contains pin assignments for the TMP1962F10AXBG as well as brief description of the TMP1962F10AXBG input and output signals.

2.1 Pin Assignment

The following illustrates the TMP1962F10AXBG pin assignment.

A1	A2	A3	A4	A5	A6	A7	A8	A9	A10	A11	A12	A13	A14	A15	A16	A17	
B1	B2	B3	B4	B5	B6	B7	B8	B9	B10	B11	B12	B13	B14	B15	B16	B17	B18
C1	C2	C3	C4	C5	C6	C7	C8	C9	C10	C11	C12	C13	C14	C15	C16	C17	C18
D1	D2	D3	D4	D5	D6	D7	D8	D9	D10	D11	D12	D13	D14	D15	D16	D17	D18
E1	E2	E3	E4	E5	E6	E7	E8	E9	E10	E11	E12	E13	E14	E15	E16	E17	E18
F1	F2	F3	F4	F5		F7	F8	F9	F10	F11	F12		F14	F15	F16	F17	F18
G1	G2	G3	G4	G5	G6							G13	G14	G15	G16	G17	G18
H1	H2	H3	H4	H5	H6							H13	H14	H15	H16	H17	H18
J1	J2	J3	J4	J5	J6							J13	J14	J15	J16	J17	J18
K1	K2	K3	K4	K5	K6							K13	K14	K15	K16	K17	K18
L1	L2	L3	L4	L5	L6							L13	L14	L15	L16	L17	L18
M1	M2	M3	M4	M5	M6							M13	M14	M15	M16	M17	M18
N1	N2	N3	N4	N5		N7	N8	N9	N10	N11	N12		N14	N15	N16	N17	N18
P1	P2	P3	P4	P5	P6	P7	P8	P9	P10	P11	P12	P13	P14	P15	P16	P17	P18
R1	R2	R3	R4	R5	R6	R7	R8	R9	R10	R11	R12	R13	R14	R15	R16	R17	R18
T1	T2	T3	T4	T5	T6	T7	T8	T9	T10	T11	T12	T13	T14	T15	T16	T17	T18
U1	U2	U3	U4	U5	U6	U7	U8	U9	U10	U11	U12	U13	U14	U15	U16	U17	U18
	V2	V3	V4	V5	V6	V7	V8	V9	V10	V11	V12	V13	V14	V15	V16	V17	

Figure 2.1 Pin Assignment (P-FBGA281)

The following provides a pin cross reference by pin number.

Table 2.1 Pin Cross Reference by Pin Number (1/2)

Pin No.	Pin Name	Pin No.	Pin Name	Pin No.	Pin Name	Pin No.	Pin Name	Pin No.	Pin Name
A1	NC	A13	PK1/KEY1	B8	P75/AIN5	C2	PCST3 (DSU)	C14	PK6/KEY6
A2	VREFL	A14	PI1/INT1	B9	PL0/TA4IN	C3	P92/AIN18	C15	PI5/INT9
A3	P90/AIN16	A15	PI3/INT3	B10	PL3/TAAIN	C4	P95/AIN21	C16	TCK (JTAG)
A4	P93/AIN19	A16	PI6/INTA	B11	PM1	C5	P82/AIN10	C17	CVCC2
A5	P80/AIN8	A17	X2	B12	PM4	C6	P85/AIN13	C18	XT2
A6	P83/AIN11	B1	AVCC31	B13	PK2/KEY2	C7	P72/AIN2	D1	SDAO/TPC (DSU)
A7	P70/AIN0	B2	VREFH	B14	PI2/INT2	C8	AVSS	D2	PCST2 (DSU)
A8	P74/AIN4	B3	P91/AIN17	B15	PI4/INT4	C9	PL1/TA6IN	D3	SDI/DINT (DSU)
A9	NC	B4	P94/AIN20	B16	PI7	C10	PL4/TB0IN0	D4	DVCC2
A10	PL2/TA8IN	B5	P81/AIN9	B17	CVSS	C11	PM2	D5	P96/AIN22
A11	PM0	B6	P84/AIN12	B18	X1	C12	PM5	D6	P86/AIN14
A12	PK0/KEY0	B7	P71/AIN1	C1	PCST0 (DSU)	C13	PK3/KEY3	D7	P73/AIN3

Table 2.1 Pin Cross Reference by Pin Number (2/2)

Pin No.	Pin Name	Pin No.	Pin Name	Pin No.	Pin Name	Pin No.	Pin Name	Pin No.	Pin Name
D8	DVCC2	F18	P44/SCOUT	K14	P12/D10/AD10	N18	DVSS	T8	PD4/TXD4
D9	DVSS	G1	RESET	K15	P13/D11/AD11	P1	PP0	T9	PC0/TXD0
D10	PL5/TB0IN1	G2	TEST5	K16	P14/D12/AD12	P2	PB2/TB2IN0/INT5	T10	PC3/TXD1
D11	PM3	G3	FVCC2	K17	DVCC33	P3	PB3/TB2IN1/INT6	T11	PH4/TCOUT4
D12	PM6	G4	FVSS	K18	P15/D13/AD13	P4	PB4/TB2OUT	T12	PE2/SCLK5/CTS5
D13	PK4/KEY4	G5	PJ0/INT0	L1	FVCC3	P5	PB5/TB3IN0/INT7	T13	PE5/KEYB
D14	PK7/KEY7	G6	BW0	L2	PO1	P6	PG5/TC5IN	T14	P53/A3
D15	DVCC34	G13	TRST	L3	PO2	P7	PG7/TC7IN	T15	P56/A6
D16	TDI (JTAG)	G14	CAP1	L4	PO3	P8	PD6/SCLK4/CTS4	T16	P62/A10
D17	TDO (JTAG)	G15	P41/CS1	L5	PO4	P9	PC2/SCLK0/CTS0	T17	P65/A13
D18	XT1	G16	P37/ALE	L6	PO7	P10	PC5/SCLK1/CTS1	T18	P20/A16/A0
E1	DCLK (DSU)	G17	P35/BUSAK	L13	TEST3	P11	PH6/TCOUT6	U1	PA0/TA0IN
E2	PCST1 (DSU)	G18	FVCC2	L14	P06/D6/AD6	P12	NC	U2	PA3/TA3OUT
E3	DBGE	H1	NMI	L15	FVCC2	P13	P50/A0	U3	PA6/TA9OUT
E4	PJ3/INTLV	H2	DVCC31	L16	P07/D7/AD7	P14	P51/A1	U4	PF1/SI/SCL
E5	PJ4/ENDIAN	H3	PN7	L17	P10/D8/AD8	P15	P54/A4	U5	PF5/DREQ3
E6	P97/AIN23	H4	BW1	L18	P11/D9/AD9	P16	P23/A19/A3	U6	PG2/TC2IN
E7	P87/AIN15	H5	PLLOFF	M1	PO0	P17	P24/A20/A4	U7	PD2/RXD3
E8	P76/AIN6	H6	TEST1	M2	PP5	P18	P25/A21/A5	U8	DVCC32
E9	P77/AIN7	H13	TEST2	M3	PP6	R1	PB0/TB0OUT	U9	PC7/RXD2
E10	PL6/TB1IN0	H14	P31/WR	M4	PP7	R2	PB1/TB1OUT	U10	PH1/TCOUT1
E11	PL7/TB1IN1	H15	P32/HWR	M5	PB7/TB3OUT	R3	PF3/DREQ2	U11	PH3/TCOUT3
E12	PM7	H16	P33/WAIT/RDY	M6	DVCC32	R4	PF4/DACK2	U12	PE1/RXD5
E13	PK5/KEY5	H17	P30/RD	M13	TEST4	R5	PF7/TBTIN	U13	PE4/KEYA
E14	NC	H18	P40/CS0	M14	P02/D2/AD2	R6	PG4/TC4IN	U14	DVCC32
E15	TMS (JTAG)	J1	PN2/SCLK6/CTS6	M15	FVSS	R7	PG6/TC6IN	U15	P57/A7
E16	CVCCH	J2	PN3	M16	P03/D3/AD3	R8	PD5/RXD4	U16	P63/A11
E17	NC	J3	PN4	M17	P04/D4/AD4	R9	PC1/RXD0	U17	P66/A14
E18	DVCC2	J4	PN5	M18	P05/D5/AD5	R10	PC4/RXD1	U18	DVCC33
F1	DVSS	J5	PN6	N1	PP1	R11	PH5/TCOUT5	V2	PA2/TA2IN
F2	DRESET	J6	DVCC2	N2	PP2	R12	PH7/TCOUT7	V3	PA5/TA7OUT
F3	SYSRDY	J13	FVSS	N3	PP3	R13	PE6/KEYC	V4	PF0/SO/SDA
F4	PJ1/BUSMD	J14	P16/D14/AD14	N4	PP4	R14	P52/A2	V5	PG0/TC0IN
F5	PJ2/BOOT	J15	DVSS	N5	PB6/TB3IN1/INT8	R15	P55/A5	V6	PG1/TC1IN
F7	AVSS	J16	P17/D15/AD15	N7	DVSS	R16	P61/A9	V7	PD1/TXD3
F8	AVSS	J17	P36/R/W	N8	PD7/KEY8	R17	P21/A17/A1	V8	PD0/SCLK2/CTS2
F9	AVCC32	J18	P34/BUSRQ	N9	DVCC2	R18	P22/A18/A2	V9	PC6/TXD2
F10	DVCC34	K1	PN0/TXD6	N10	DVSS	T1	PA1/TA1OUT	V10	PH0/TCOUT0
F11	PI0/ADTRG	K2	PN1/RXD6	N11	RSTPUP	T2	PA4/TA5OUT	V11	PH2/TCOUT2
F12	DVSS	K3	PO5	N12	DVSS	T3	PA7/TABOUT	V12	PE0/TXD5
F14	CAP2	K4	PO6	N14	P26/A22/A6	T4	PF2/SCK	V13	PE3/KEY9
F15	P42/CS2	K5	FVSS	N15	P27/A23/A7	T5	PF6/DACK3	V14	PE7/KEYD
F16	P43/CS3	K6	DVSS	N16	P00/D0/AD0	T6	PG3/TC3IN	V15	P60/A8
F17	DVCC33	K13	TEST0	N17	P01/D1/AD1	T7	PD3/SCLK3/CTS3	V16	P64/A12
								V17	P67/A15

2.2 Pin Usage Information

Table 2.2 lists input and output pins of the TMP1962F10AXBG.

Table 2.2 Pin Names and Function (1/6)

Pin Name	# of Pins	Type	Function
P00-P07 D0-D7 AD0-D7	8	Input/Output Input/Output Input/Output	Port 0: Individually programmable input or output Data (Lower): Bits 0-7 of the data bus (separate bus mode) Address /Data (Lower): Bits 0-7 of the address/data bus (multiplex bus mode)
P10-P17 D8-D15 AD8-AD15 A8-A15	8	Input/Output Input/Output Input/Output Output	Port 1: Individually programmable input or output Data (Upper): Bits 8-15 of the data bus (separate bus mode) Address /Data (Upper): Bits 8-15 of the address/data bus (multiplex bus mode) Address: Bits 8-15 of the address bus (multiplex bus mode)
P20-P27 A16-A23 A0-A7 A16-A23	8	Input/Output Output Output Output	Port 2: Individually programmable input or output Address: Bit 15-23 of the address bus (separate bus mode) Address: Bit 0-7 of the address bus (multiplex bus mode) Address: Bit 16-23 of the address bus (multiplex bus mode)
P30 \overline{RD}	1	Output Output	Port 30: Output-only Read Strobe: Asserted during a read operation from an external memory device
P31 \overline{WR}	1	Output Output	Port 31: Output-only Write Strobe: Asserted during a write operation on D0-D7
P32 \overline{HWR}	1	Input/Output Output	Port 32: Programmable as input or output (with internal pull-up register) Higher Write Strobe: Asserted during a write operation on D8-D15
P33 \overline{WAIT} \overline{RDY}	1	Input/Output Input Input	Port 33: Programmable as input or output (with internal pull-up resistor) Wait: Causes the CPU to suspend external bus activity Ready: Informs the CPU of bus ready condition
P34 \overline{BUSRQ}	1	Input/Output Input	Port 34: Programmable as input or output (with internal pull-up resistor) Bus Request: Asserted by an external bus master to request bus mastership
P35 \overline{BUSAK}	1	Input/Output Output	Port 35: Programmable as input or output (with internal pull-up resistor) Bus Acknowledge: Indicates that the CPU has relinquished the bus in response to \overline{BUSRQ} .
P36 R/\overline{W}	1	Input/Output Output	Port 36: Programmable as input or output (with internal pull-up resistor) Read/Write: Indicates the direction of data transfer on the bus: 1 = read or dummy cycle, 0 = write cycle
P37 ALE	1	Input/Output Output	Port 37: Programmable as input or output Address Latch Enable (This signal is driven out only when external memory is accessed.)
P40 $\overline{CS0}$	1	Input/Output Output	Port 40: Programmable as input or output (with internal pull-up resistor) Chip Select 0: Asserted low to enable external devices at programmed addresses
P41 $\overline{CS1}$	1	Input/Output Output	Port 41: Programmable as input or output (with internal pull-up resistor) Chip Select 1: Asserted low to enable external devices at programmed addresses
P42 $\overline{CS2}$	1	Input/Output Output	Port 42: Programmable as input or output (with internal pull-up resistor) Chip Select 2: Asserted low to enable external devices at programmed addresses
P43 $\overline{CS3}$	1	Input/Output Output	Port 43: Programmable as input or output (with internal pull-up resistor) Chip Select 3: Asserted low to enable external devices at programmed addresses
P44 SCOUT	1	Input/Output Output	Port 44: Programmable as input or output System Clock Output: Drives out a clock signal at the frequency equal to or one half of CPU clock (high-speed or low-speed)
P50-P57 A0-A7	8	Input/Output Output	Port 5: Individually programmable as input or output Address: Address bus 0-7 (separate bus mode)
P60-P67 A8-A15	8	Input/Output Output	Port 6: Individually programmable as input or output Address: Address bus 8-15 (separate bus mode)
P70-P77 AN0-AN7	8	Input Input	Port 7: Input-only Analog Input: Input to the on-chip A/D converter
P80-P87 AN8-AN15	8	Input Input	Port 8: Input-only Analog Input: Input to the on-chip A/D converter

Table 2.2 Pin Names and Function (2/6)

Pin Name	# of Pins	Type	Function
P90-P97 AN16-AN23	8	Input Input	Port 9: Input-only Analog Input: Input to the on-chip A/D converter
PI0 $\overline{\text{ADTRG}}$	1	Input/Output Input	Port I0: Programmable as input or output AD Trigger: Starts an A/D conversion Schmitt trigger input
PI1 INT1	1	Input/Output Input	Port I1: Programmable as input or output Interrupt Request 1: Programmable to be high-level, low-level, rising-edge or falling-edge sensitive Schmitt trigger input
PI2 INT2	1	Input/Output Input	Port I2: Programmable as input or output Interrupt Request 2: Programmable to be high-level, low-level, rising-edge or falling-edge sensitive Schmitt trigger input
PI3 INT3	1	Input/Output Input	Port I3: Programmable as input or output Interrupt Request 3: Programmable to be high-level, low-level, rising-edge or falling-edge sensitive Schmitt trigger input
PI4 INT4	1	Input/Output Input	Port I4: Programmable as input or output Interrupt Request 4: Programmable to be high-level, low-level, rising-edge or falling-edge sensitive Schmitt trigger input
PI5 INT9	1	Input/Output Input	Port I5: Programmable as input or output Interrupt Request 9: Programmable to be high-level, low-level, rising-edge or falling-edge sensitive Schmitt trigger input
PI6 INTA	1	Input/Output Input	Port I6: Programmable as input or output Interrupt Request A: Programmable to be high-level, low-level, rising-edge or falling-edge sensitive Schmitt trigger input
PI7	1	Input/Output	Port I7: Programmable as input or output
PA0 TA0IN	1	Input/Output Input	Port A0: Programmable as input or output 8-Bit Timer 0 Input: Input to 8-bit Timer 0
PA1 TA1OUT	1	Input/Output Output	Port A1: Programmable as input or output 8-Bit Timer 01 Output: Output from either 8-bit Timer 0 or Timer 1
PA2 TA2IN	1	Input/Output Input	Port A2: Programmable as input or output 8-Bit Timer 2 Input: Input to 8-bit Timer 2
PA3 TA3OUT	1	Input/Output Output	Port A3: Programmable as input or output 8-Bit Timer 23 Output: Output from either 8-bit Timer 2 or Timer 3
PA4 TA5OUT	1	Input/Output Output	Port A4: Programmable as input or output 8-Bit Timer 45 Output: Output from either 8-bit Timer 4 or Timer 5
PA5 TA7OUT	1	Input/Output Output	Port A5: Programmable as input or output 8-Bit Timer 67 Output: Output from either 8-bit Timer 6 or Timer 7
PA6 TA9OUT	1	Input/Output Input	Port A6: Programmable as input or output 8-Bit Timer 89 Output: Output from either 8-bit Timer 8 or Timer 9
PA7 TABOUT	1	Input/Output Output	Port A7: Programmable as input or output 8-Bit Timer AB Output: Output from either 8-bit Timer A or Timer B
PB0 TB0OUT	1	Input/Output Output	Port B0: Programmable as input or output 16-Bit Timer 0 Output: Output from 16-bit Timer 0
PB1 TB1OUT	1	Input/Output Output	Port B1: Programmable as input or output 16-Bit Timer 1 Output: Output from 16-bit Timer 1
PB2 TB2IN0 INT5	1	Input/Output Input Input	Port B2: Programmable as input or output 16-Bit Timer 2 Input 0: Count/capture trigger input to 16-bit Timer 2 Interrupt Request 5: Programmable to be high-level, low-level, rising-edge or falling-edge sensitive

Table 2.2 Pin Names and Function (3/6)

Pin Name	# of Pins	Type	Function
PB3 TB2IN1 INT6	1	Input/Output Input Input	Port B3: Programmable as input or output 16-Bit Timer 2 Input 1: Capture trigger input to 16-bit Timer 2 Interrupt Request 6: Programmable to be high-level, low-level, rising-edge or falling-edge sensitive
PB4 TB2OUT	1	Input/Output Output	Port B4: Programmable as input or output 16-Bit Timer 2 Output: Output from 16-bit Timer 2
PB5 TB3IN0 INT7	1	Input/Output Input Input	Port B5: Programmable as input or output 16-Bit Timer 3 Input 0: Count/capture trigger input to 16-bit Timer 3 Interrupt Request 7: Programmable to be high-level, low-level, rising-edge or falling-edge sensitive
PB6 TB3IN1 INT8	1	Input/Output Input Input	Port B6: Programmable as input or output 16-Bit Timer 3 Input 1: Capture trigger input to 16-bit Timer 3 Interrupt Request 8: Programmable to be high-level, low-level, rising-edge or falling-edge sensitive
PB7 TB3OUT	1	Input/Output Output	Port B7: Programmable as input or output 16-Bit Timer 3 Output: Output from 16-bit Timer 3
PC0 TXD0	1	Input/Output Output	Port C0: Programmable as input or output Serial Transmit Data 0: Programmable as a push-pull or open-drain output
PC1 RXD0	1	Input/Output Input	Port C1: Programmable as input or output Serial Receive Data 0
PC2 SCLK0 $\overline{\text{CTS0}}$	1	Input/Output Input Input	Port C2: Programmable as input or output Serial Clock Input/Output 0 Serial Clear-to-Send 0 Programmable as a push-pull or open-drain output
PC3 TXD1	1	Input/Output Output	Port C3: Programmable as input or output Serial Transmit Data 1: Programmable as a push-pull or open-drain output
PC4 RXD1	1	Input/Output Input	Port C4: Programmable as input or output Serial Receive Data 1
PC5 SCLK1 $\overline{\text{CTS1}}$	1	Input/Output Input Input	Port C5: Programmable as input or output Serial Clock Input/Output 1 Serial Clear-to-Send 1 Programmable as a push-pull or open-drain output
PC6 TXD2	1	Input/Output Output	Port C6: Programmable as input or output Serial Transmit Data 2: Programmable as a push-pull or open-drain output
PC7 RXD2	1	Input/Output Input	Port C7: Programmable as input or output Serial Receive Data 2
PD0 SCLK2 $\overline{\text{CTS2}}$	1	Input/Output Input Input	Port D0: Programmable as input or output Serial Clock Input/Output 2 Serial Clear-to-Send 2 Programmable as a push-pull or open-drain output
PD1 TXD3	1	Input/Output Output	Port D1: Programmable as input or output Serial Transmit Data 3: Programmable as a push-pull or open-drain output
PD2 RXD3	1	Input/Output Input	Port D2: Programmable as input or output Serial Receive Data 3
PD3 SCLK3 $\overline{\text{CTS3}}$	1	Input/Output Input Input	Port D3: Programmable as input or output Serial Clock Input/Output 3 Serial Clear-to-Send 3 Programmable as a push-pull or open-drain output
PD4 TXD4	1	Input/Output Output	Port D4: Programmable as input or output Serial Transmit Data 4: Programmable as a push-pull or open-drain output
PD5 RXD4	1	Input/Output Input	Port D5: Programmable as input or output Serial Receive Data 4
PD6 SCLK4 $\overline{\text{CTS4}}$	1	Input/Output Input Input	Port D6: Programmable as input or output Serial Clock Input/Output 4 Serial Clear-to-Send 4 Programmable as a push-pull or open-drain output
PD7 KEY8	1	Input/Output Input	Port D7: Programmable as input or output KEY on wake up Input 8: (dynamic pull-up selectable) (with internal pull-up register) Schmitt trigger input

Table 2.2 Pin Names and Function (4/6)

Pin Name	# of Pins	Type	Function
PE0 TXD5	1	Input/Output Output	Port E0: Programmable as input or output Serial Transmit Data 5: Programmable as a push-pull or open-drain output
PE1 RXD5	1	Input/Output Input	Port E1: Programmable as input or output Serial Receive Data 5
PE2 SCLK5 $\overline{\text{CTS5}}$	1	Input/Output Input Input	Port E2: Programmable as input or output Serial Clock Input/Output 5 Serial Clear-to-Send 5 Programmable as a push-pull or open-drain output
PE3 KEY9	1	Input/Output Input	Port E3: Programmable as input or output KEY on wake up Input 9: (dynamic pull-up selectable) (with internal pull-up register) Schmitt trigger input
PE4 KEYA	1	Input/Output Input	Port E4: Programmable as input or output KEY on wake up Input A: (dynamic pull-up selectable) (with internal pull-up register) Schmitt trigger input
PE5 KEYB	1	Input/Output Input	Port E5: Programmable as input or output KEY on wake up Input B: (dynamic pull-up selectable) (with internal pull-up register) Schmitt trigger input
PE6 KEYC	1	Input/Output Input	Port E6: Programmable as input or output KEY on wake up Input C: (dynamic pull-up selectable) (with internal pull-up register) Schmitt trigger input
PE7 KEYD	1	Input/Output Input	Port C7: Programmable as input or output KEY on wake up Input D: (dynamic pull-up selectable) (with internal pull-up register) Schmitt trigger input
PF0 SO SDA	1	Input/Output Output Input/Output	Port F0: Programmable as input or output Data transmit pin when the Serial Bus Interface is in SIO mode Data transmit/receive pin when the Serial Bus Interface is in I2C mode; programmable as a push-pull or open-drain output Schmitt trigger input
PF1 SI SCL	1	Input/Output Input Input/Output	Port F1: Programmable as input or output Data receive pin when the Serial Bus Interface is in SIO mode Clock input/output pin when the Serial Bus Interface is in I2C mode; programmable as a push-pull or open-drain output Schmitt trigger input
PF2 SCK	1	Input/Output Input/Output	Port F2: Programmable as input or output Clock input/output pin when the Serial Bus Interface is in SIO mode
PF3 $\overline{\text{DREQ2}}$	1	Input/Output Input	Port F3: Programmable as input or output DMA Request 2: DMA transfer request from an external I/O device to DMAC2
PF4 $\overline{\text{DACK2}}$	1	Input/Output Output	Port F4: Programmable as input or output DMA Acknowledge 2: Acknowledge signal for DMA transfer requested by DREQ2
PF5 $\overline{\text{DREQ3}}$	1	Input/Output Input	Port F5: Programmable as input or output DMA Request 3: DMA transfer request from an external I/O device to DMAC3
PF6 $\overline{\text{DACK3}}$	1	Input/Output Output	Port F6: Programmable as input or output DMA Acknowledge 3: Acknowledge signal for DMA transfer requested by DREQ3
PF7 TBTIN	1	Input/Output Input	Port F7: Programmable as input or output 32-bit Time-Base Timer Input: Count input to 32-bit time-base Timer
PG0-PG7 TC0IN-TC7IN	8	Input/Output Input	Port G: Individually programmable as input or output 32-Bit Timer Capture Trigger Input
PH0-PH7 TCOUT0-TCO UT7	8	Input/Output Output	Port H: Individually programmable as input or output 32-Bit Timer Compare Match Output
PJ0 INT0	1	Input/Output Input	Port J0: Programmable as input or output Interrupt Request 0: Programmable to be high-level, low-level, rising-edge or falling-edge sensitive Schmitt trigger input

Table 2.2 Pin Names and Function (5/6)

Pin Name	# of Pins	Type	Function
PJ1 BUSMD	1	Input/Output Input	Port J1: Programmable as input or output External Bus Mode: If this pin is sampled high (DVCC21) at the rising edge of RESET, the TMP1962F10AXBG enters multiplex bus mode. If this pin is sampled low at the rising edge of RESET, the TMP1962F10AXBG enters separate bus mode. During a reset sequence, this pin should be pulled up to a logic 1 or pulled down to a logic 0 depending on the bus mode to be used.
PJ2 <u>BOOT</u>	1	Input/Output Input	Port J2: Programmable as input or output Single Boot Mode: If this pin is sampled low at the rising edge of RESET, the TMP1962F10AXBG enters Single Boot mode for re-programming of the on-chip flash. If this pin is sampled high (DVCC21) at the rising edge of RESET, the TMP1962F10AXBG enters NORMAL mode. During a reset sequence, this pin should be pulled up to a logic 1 commonly.
PJ3 INTLV	1	Input/Output Input	Port J3: Programmable as input or output Interleave Mode: The TMP1962F10AXBG enters Interleave mode when this pin is sampled high (DVCC21) at the rising edge of RESET. During a reset sequence, this pin should be pulled up to a logic 1.
PJ4 ENDIAN	1	Input/Output Input	Port J4: Programmable as input or output This pin is used to set the mode. If this pin is sampled high (DVCC21) at the rising edge of RESET, the TMP1962F10AXBG enters Big-endian mode. If this pin is sampled low at the rising edge of RESET, the TMP1962F10AXBG enters Little-endian mode. During a reset sequence, this pin should be pulled up to a logic 1 or pulled down to a logic 0 depending the endian to be used.
PK0-PK7 KEY0-KEY7	8	Input/Output Input	Port K: Programmable as input or output Key on wake up input 0-7 (dynamic pull-up selectable) (with internal pull-up register) Schmitt trigger input
PL0 TA4IN	1	Input/Output Input	Port L0: Programmable as input or output 8-bit Timer 4 Input: Input to 8-bit Timer 4
PL1 TA6IN	1	Input/Output Input	Port L1: Programmable as input or output 8-bit Timer 6 Input: Input to 8-bit Timer 6
PL2 TA8IN	1	Input/Output Input	Port L2: Programmable as input or output 8-bit Timer 8 Input: Input to 8-bit Timer 8
PL3 TAAIN	1	Input/Output Input	Port L3: Programmable as input or output 8-bit Timer A Input: Input to 8-bit Timer A
PL4 TB0IN0	1	Input/Output Input	Port L4: Programmable as input or output 16-Bit Timer 0 Input 0: Count/capture trigger input to 16-bit Timer 0
PL5 TB0IN1	1	Input/Output Input	Port L5: Programmable as input or output 16-Bit Timer 0 Input 1: Capture trigger input to 16-bit Timer 0
PL6 TB1IN0	1	Input/Output Input	Port L6: Programmable as input or output 16-Bit Timer 1 Input 0: Count/capture trigger input to 16-bit Timer 1
PL7 TB1IN1	1	Input/Output Input	Port L7: Programmable as input or output 16-Bit Timer 1 Input 1: Capture trigger input to 16-bit Timer 1
PM0-PM7	8	Input/Output	Port M: Individually programmable input or output
PN0 TXD6	1	Input/Output Output	Port N0: Programmable as input or output Serial Transmit Data 6: Programmable as a push-pull or open-drain output
PN1 RXD6	1	Input/Output Input	Port N1: Programmable as input or output Serial Receive Data 6
PN2 SCLK6 <u>CTS6</u>	1	Input/Output Input Input	Port N2: Programmable as input or output Serial Clock Input/Output 6 Serial Clear-to-Send 6 Programmable as a push-pull or open-drain output
PN3-PN7	5	Input/Output	Port N3-N7: Individually programmable input or output
PO0-PO7	8	Input/Output	Port O: Individually programmable input or output
PP0-PP7	8	Input/Output	Port P: Individually programmable input or output

Table 2.2 Pin Names and Function (6/6)

Pin Name	# of Pins	Type	Function
NMI	1	Input	Nonmaskable Interrupt Request: Causes an NMI interrupt on the falling edge
PLLOFF	1	Input	This pin should be tied to High (DVCC21) when the frequency multiplied clock from the PLL is used; Otherwise, it should be tied to Low. Schmitt trigger input
RSTPUP	1	Input	During a reset sequence, Port 3 and Port 4 are pull-up enabled if this pin is sampled High (DVCC32), and disabled if this pin is sampled Low. Schmitt trigger input
RESET	1	Input	Reset (with internal pull-up register): Initializes the whole TMP1962F10AXBG Schmitt trigger input
X1/X2	2	Input/Output	Connection pins for a high-speed crystal
XT1/XT2	2	Input/Output	This pin should be left open.
DRESET	1	Input	Debug Reset: Signal for DSU-ICE (Schmitt trigger input, with internal pull-up register)
DCLK	1	Output	Debug Clock: Signal for DSU-ICE
DBG \bar{E}	1	Input	Debug Enable: Signal for DSU-ICE (Schmitt trigger input, with internal pull-up register)
PCST3-0	4	Output	PC Trace Status: Signal for DSU-ICE
SDI/ \bar{DINT}	1	Input	Serial Data Input/Debug Interrupt: Signal for DSU-ICE (Schmitt trigger input, with internal pull-up register)
SDAO/TPC	1	Output	Serial Data and Address Output/Target PC: Signal for DSU-ICE
TCK	1	Input	Test Clock Input: Signal for JTAG test (Schmitt trigger input, with internal pull-up register)
TMS	1	Input	Test Mode Select Input: Signal for JTAG test (Schmitt trigger input, with internal pull-up register)
TDI	1	Input	Test Data Input: Signal for JTAG test (Schmitt trigger input, with internal pull-up register)
TDO	1	Output	Test Data Output: Signal for JTAG test
\bar{TRST}	1	Input	Test Reset Input: Signal for JTAG test (Schmitt trigger input, with internal pull-up register)
BW0-1	2	Input	Both BW0 and BW1 should be tied to High (DVCC21). (Schmitt trigger input)
VREFH	1	Input	Input pin for high reference voltage for the A/D Converter This pin should be connected to the AVCC pin when the A/D Converter is not used.
VREFL	1	Input	Input pin for low reference voltage for the A/D Converter This pin should be connected to the AVCC pin when the A/D Converter is not used.
AVCC31-32	2	—	Power supply pins for the A/D Converter. These pins should always be connected to power supply even when the A/D Converter is not used.
AVSS	3	—	Ground pins for the A/D Converter. These pins should always be connected to ground even when the A/D Converter is not used.
TEST0	1	—	Test pin: This pin should be left open or tied to ground.
TEST1	1	Input	Test pin: This pin should be tied to ground.
TEST2	1	—	Test pin: This pin should be left open or tied to ground.
TEST3	1	—	Test pin: This pin should be left open or tied to ground.
TEST4	1	—	Test pin: This pin should be left open or tied to ground.
TEST5	1	Input	Test pin: This pin should be tied to ground.
SYSRDY	1	Output	Signal to grant access to a flash memory
CVCC2	1	—	Power supply pins for an oscillator: 2.5 V
CVSS	1	—	Ground pin for an oscillator (0 V)
CVCCH	1	—	This pin should be left open.
CAP1	1	—	This pin should be left open.
CAP2	1	—	This pin should be left open.
FVCC2	3	—	Power supply pins for a Flash memory: 2.5 V
FVCC3	1	—	Power supply pin for a flash memory: 3 V
FVSS	4	—	Ground pins for a flash memory (0 V)
DVCC21-22	5	—	Power supply pins: 2.5 V
DVCC31-34	9	—	Power supply pins: 3 V
DVSS	9	—	Ground pins (0V)

Note 1: PJ1, PJ2, PJ3 and PJ4 should be held at the prescribed logic states for one system clock cycle before and after the rising edge of RESET, with the RESET signal being stable in either logic state.

Note 2: Debugging with a DSU-probe is enabled on the TMP1962F10AXBG. Connection to the DSU-probe is available on the TMP1962C10BxBG, but a DSU-probe can not read the contents of on-chip ROM or write to registers other than the processor core, on-chip memory and external device.

Table 2.3 shows correspondence between pins and power supply pins.

Table 2.3 Pins and Corresponding Power Supply Pins

Pin	Power Supply		Pin	Power Supply	
	Mask Type	Flash Type		Mask Type	Flash Type
P0	DVCC33	DVCC33	PO	DVCC31	DVCC31
P1	DVCC33	DVCC33	PP	DVCC31	DVCC31
P2	DVCC33	DVCC33	X1	CVCC15	CVCC2
P3	DVCC33	DVCC33	X2	CVCC15	CVCC2
P4	DVCC33	DVCC33	RESET	DVCC2	DVCC21
P5	DVCC33	DVCC33	NMI	DVCC2	DVCC21
P6	DVCC33	DVCC33	PLLOFF	DVCC2	DVCC21
P7	AVCC32	AVCC32	DRESET	DVCC2	DVCC21
P8	AVCC32	AVCC32	DCLK	DVCC2	DVCC21
P9	AVCC31	AVCC31	DBG \bar{E}	DVCC2	DVCC21
PA	DVCC32	DVCC32	PCST3-0	DVCC2	DVCC21
PB	DVCC32	DVCC32	SDI/DINT	DVCC2	DVCC21
PC	DVCC32	DVCC32	SDAO/TPC	DVCC2	DVCC21
PD	DVCC32	DVCC32	TCK	DVCC34	DVCC34
PE	DVCC32	DVCC32	TMS	DVCC34	DVCC34
PF	DVCC32	DVCC32	TDI	DVCC34	DVCC34
PG	DVCC32	DVCC32	TDO	DVCC34	DVCC34
PH	DVCC32	DVCC32	TRST	DVCC34	DVCC34
PI	DVCC34	DVCC34	BW1-0	DVCC2	DVCC21
PJ	DVCC2	DVCC21	RSTPUP	DVCC32	DVCC32
PK	DVCC34	DVCC34			
PL	DVCC34	DVCC34			
PM	DVCC34	DVCC34			
PN	DVCC31	DVCC31			

Table 2.4 shows the supply voltage for power supply pins.

Table 2.4 Supply Voltage for Power Supply Pins

Power Supply Pin	Supply Voltage	Applied for
DVCC15	1.35 V - 1.65 V	Mask Type
CVCC15	1.35 V - 1.65 V	
DVCC2	2.3 V - 3.3 V	
DVCC21	2.2 V - 2.7 V	Flash Type
DVCC22	2.2 V - 2.7 V	
CVCC2	2.2 V - 2.7 V	
FVCC2	2.2 V - 2.7 V	
FVCC3	2.9 V - 3.6 V	
DVCC31 - 34	1.65 V - 3.3 V	Mask/Flash Type
AVCC31 - 32	2.7 V - 3.3 V	

Note 1: AVCC32 ≤ AVCC31

- When P7 to P9 are used as A/D converter inputs: $2.7 \leq AVCC3^*$
- When P9 (powered by AVCC31) is used as an A/D converter input while P7 and P8 (powered by AVCC32) are used as ports:
 - $2.7 \text{ V} \leq AVCC31 \leq 3.3 \text{ V}$
 - $1.65 \text{ V} \leq AVCC32 \leq AVCC31$
- When P7 (powered by AVCC32) is used as an A/D converter input which P8 (powered by AVCC32) and P9 (powered by AVCC31) are used as ports:
 - $2.7 \text{ V} \leq AVCC32 \leq AVCC31 \leq 3.3 \text{ V}$

Note2: With power supplies for CPU and internal logic (mask type: DVCC15/DVCC2/DVCC15, and flash type: DVCC21/DVCC22/CVCC2/FVCC2/FVCC3) being applied, power supplies for other I/O ports can be interrupted on the TMP1962. However, when AVCC31 for analog power supply is interrupted, overlap current is generated on the TMP1962F10A with on-chip flash memory during the transition to be stable in 0 V. Overlap current can be suppressed by AD conversion of the conversion result 0 V before interrupting AVCC31 power supply, but suppress it on devices.

3. Flash Memory

This chapter describes the flash memory of the TMP1962F10AXBG, a flash version of the TMP1962C10BxBG. The TMP1962F10AXBG contains a 1-Mbyte flash EEPROM and 40-kbyte RAM whereas the TMP1962C10BxBG contains a 1-Mbyte ROM and a 40-kbyte RAM. In other respects, the hardware configuration and the functionality of the TMP1962F10AXBG are identical to those of the TMP1962C10BxBG. For descriptions of the on-chip I/O peripherals, refer to the TMP1962C10BxBG datasheet.

3.1 Features

(1) Organization

The TMP1962F10AXBG contains 8 Mbits (1024 kbytes) of flash memory, which is divided into a total of 8 blocks (128-kbyte x 8) to allow for independent protection from program and erase for each block. While the CPU can access information in the flash through a full 32-bit data bus, an external flash programmer can only perform 16-bit data bus writes to the flash.

(2) Access Types

The flash memory of the TMP1962F10AXBG provides the interleaved access type.

(3) Program/Erase Time

- Chip programming time: 15 seconds (typ.) including verify operations
- Chip erase time: 40 seconds (typ.), including verify operations

Note: These program and erase times are typical values and do not include data transfer overhead. The actual chip program and erase times depend on the programming method used.

(4) Programming Modes

Several options exist to program the TMP1962F10AXBG flash memory. On-Board Programming modes allow for re-programming of the flash memory while the chip is soldered on a printed circuit board. Programmer mode utilizes an EPROM programmer to perform code updates.

- On-Board Programming modes

1) User Boot mode

Supports use of a user-written programming algorithm.

2) Single Boot mode

Downloads the new program code using a Toshiba-defined serial interface protocol.

- Programmer Mode

Supports use of a general-purpose EPROM programmer.

(5) Re-programming

The TMP1962F10AXBG flash memory is compatible with the JEDEC standards, except a few unique functions. Thus, it is easy to migrate from a discrete flash memory device to the on-chip flash memory of the TMP1962F10AXBG. The TMP1962F10AXBG contains hardware to perform programming and erase operations automatically. This eliminates the need for the user to code complex program and erase sequences.

The security feature of the TMP1962F10AXBG flash memory prevents the stored data from being read while it is being re-programmed with programming equipment. The TMP1962F10AXBG also allows the user to protect individual blocks of the flash memory against program or erase through software commands; however, 12-V VPP programming does not support data protection on a block-by-block basis. The flash memory is secured automatically by all of 8 blocks being protected. Unsecuring the flash memory automatically erases the stored data prior to unprotecting the blocks.

JEDEC Standard	Changes and Enhancements
Auto Program	Added feature: Security Auto Program
Auto Chip Erase	Changed feature: Block protection is available only under software control.
Auto Block Erase	Removed feature: Erase Resume/Suspend mode
Auto Multi-Block Erase	
Data Polling / Toggle Bit	

3.2 Block Diagram

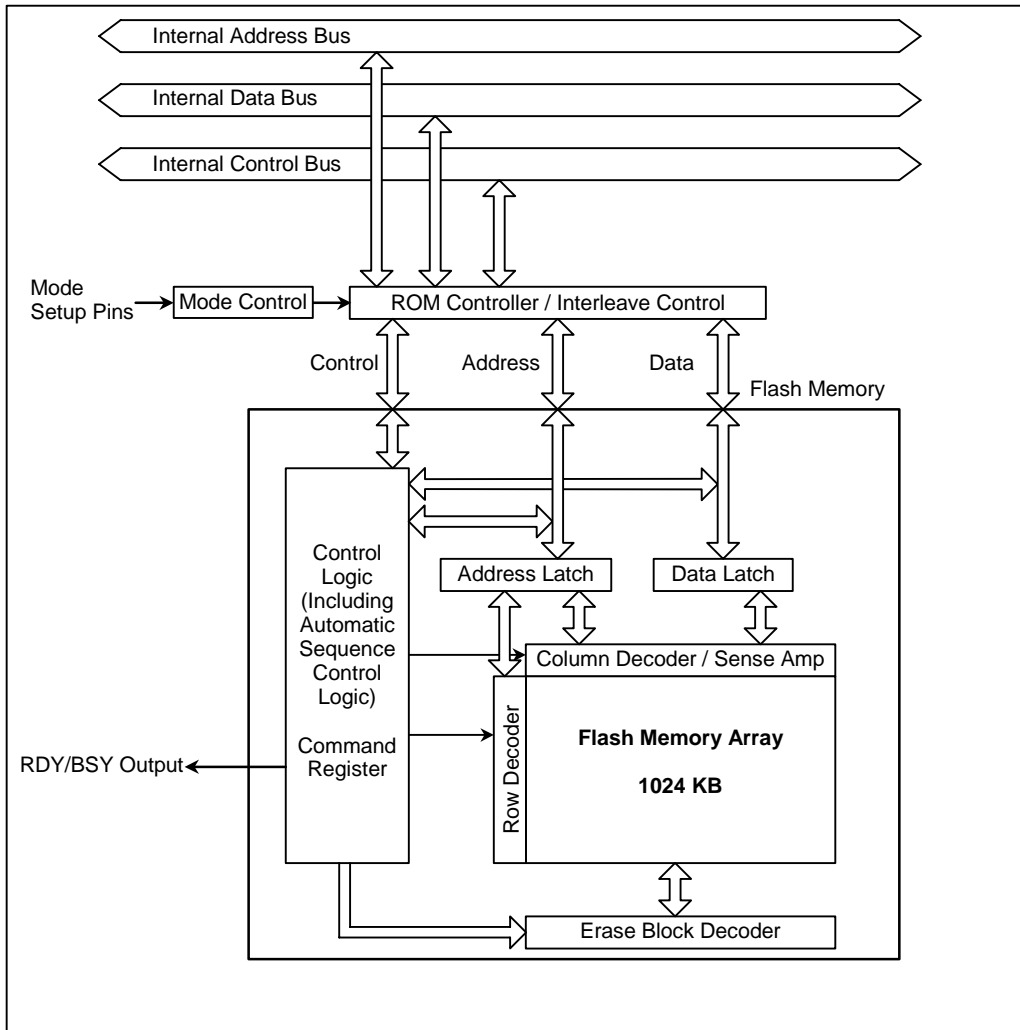

Figure 3.1 Flash Memory Block Diagram

3.3 Operating Modes

3.3.1 Overview

The TMP1962F10AXBG offers a total of five operating modes, including the one in which the flash memory is unused.

Table 3.1 Operating Modes

Operating Mode	Description
Single-Chip Mode	After a reset, the TX19 core processor executes out of the on-chip flash memory. Set the INTLV pin to High level when $\overline{\text{RESET}}$ is released.
Normal Mode	Single-Chip mode is further divided into Normal mode in which the user application executes and User Boot mode which allows for re-programming of the flash memory while the TMP1962F10AXBG is installed on a printed circuit board.
User Boot Mode	The user can freely define how to switch between Normal mode and User Boot mode. For example, the logic state on, say, Port 00, can be used to determine whether to put the flash memory in Normal mode or User Boot mode. The user must include a routine in the application program to test the state of that port.
Single Boot Mode	After a reset, the TX19 core processor executes out of the on-chip boot ROM (which is a mask ROM). The boot ROM contains a routine to aid users in performing on-board programming of the flash memory via a serial port of the TMP1962F10AXBG. The serial port is connected to an external host which transfers new data according to a prescribed protocol.
Programmer Mode	This mode allows re-programming of the flash memory with a general-purpose EPROM programmer. Use the programmer and programming adaptor recommended by Toshiba.

The on-chip flash memory can be re-programmed in one of the following three modes: User Boot mode, Single Boot mode and Programmer mode. Of these modes, User Boot mode and Single Boot mode are collectively referred to as on-board programming modes.

The logic states on the BW0, BW1, $\overline{\text{BOOT}}$ and INTLV pins during a reset sequence determine the mode of operation for the flash memory, as shown in Table 3.2. After $\overline{\text{RESET}}$ is released, PJ2 ($\overline{\text{BOOT}}$) and PA2 (INTLV) can be configured as general-purpose I/O pins.

After a reset, the CPU operates in compliance with the selected mode, except for Programmer mode. When Programmer mode is selected, $\overline{\text{RESET}}$ must be held at logic 0. The input pins listed in Table 3.2 must remain stable once the flash memory is put in a given mode of operation.

Table 3.2 Modes of Operation

#	Operating Mode	Input Pins				
		$\overline{\text{RESET}}$	BW0	BW1	$\overline{\text{RESET}}$	INTLV
(1)	Single-Chip Mode	0 → 1	1	1	1	1
(2)	Single Boot Mode	0 → 1	1	1	0	Note 1
(3)	Programmer Mode	0	0	1	Note 1	Note 1

Note 1: Don't care. The pins must be held at 1 or 0, however.

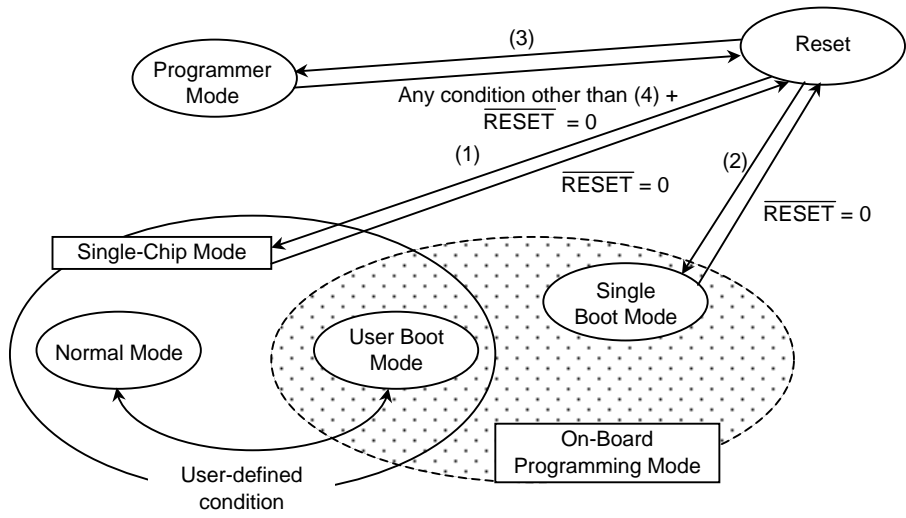

Parenthesized numbers indicate that the relevant pins are at the logic states shown in Table 3.2.

Figure 3.2 Mode Transitions

3.3.2 Reset Operation

To reset the TMP1962F10AXBG, $\overline{\text{RESET}}$ must be asserted for at least 12 system clock periods after the power supply voltage and the internal high-frequency oscillator have stabilized. This time is typically 2.37 μs at 40.5 MHz when the on-chip PLL is utilized.

3.3.3 Memory Maps

The memory map for the TMP1962F10AXBG varies according to the operation mode selected for the on-chip flash memory. Following are the memory maps in each operation mode.

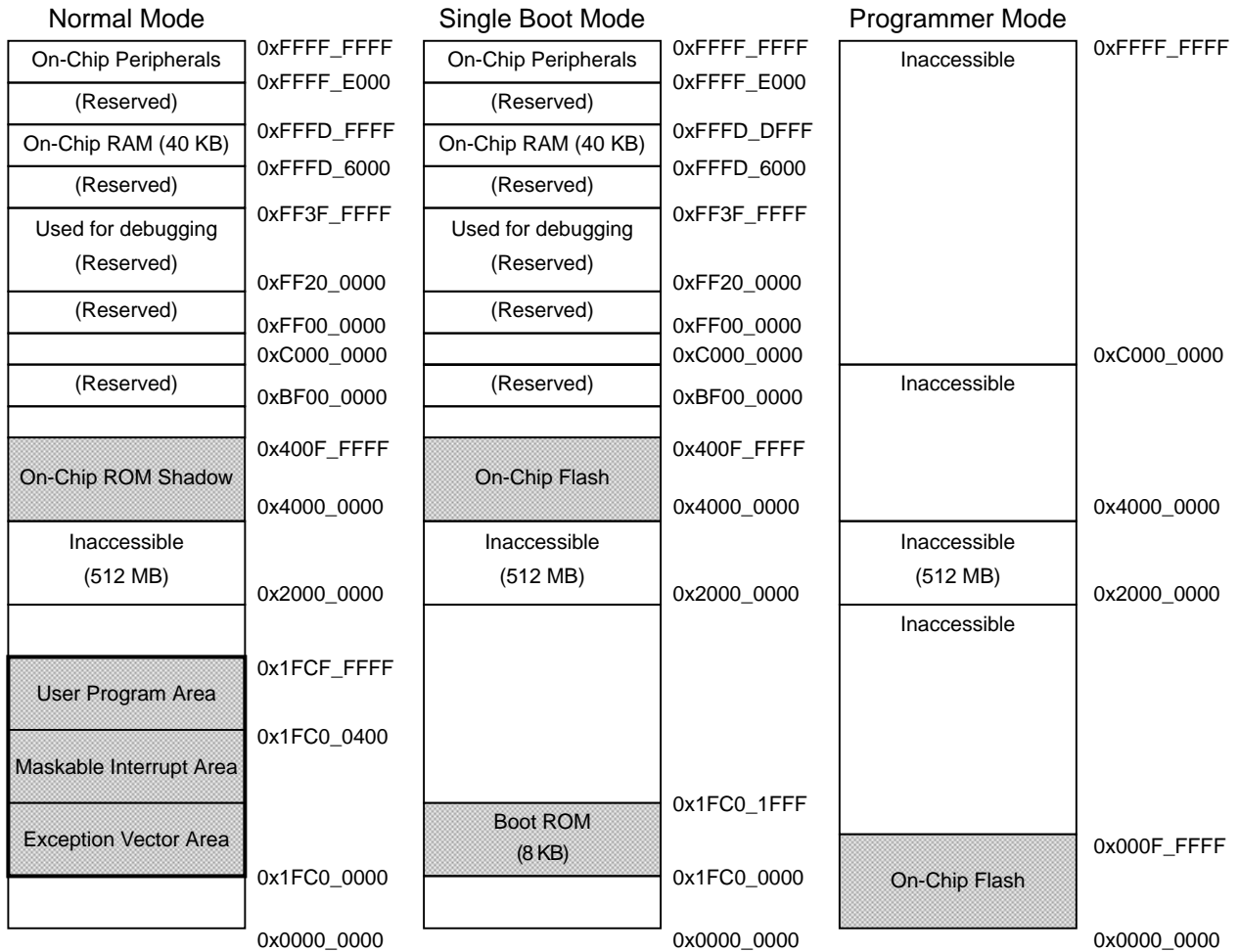

Note: The addresses shown above are physical addresses.

Figure 3.3 TMP1962F10AXBG Memory Maps

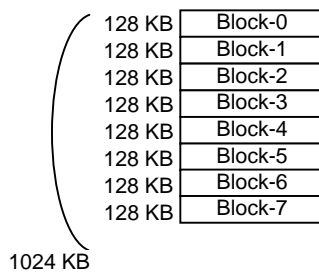

Figure 3.4 Flash Memory Block Architecture

Table 3.3 Block Addresses

	User Boot Mode	Boot Mode	Programmer Mode
Block-0	0x1FC0_0000 - 0x1FC1_FFFF (or 0x4000_0000 - 0x4001_FFFF)	0x1FC0_0000 - 0x1FC1_FFFF	0x0000_0000 - 0x0001_FFFF
Block-1	0x1FC2_0000 - 0x1FC3_FFFF (or 0x4002_0000 - 0x4003_FFFF)	0x1FC2_0000 - 0x1FC3_FFFF	0x0000_8000 - 0x0003_FFFF
Block-2	0x1FC4_0000 - 0x1FC5_FFFF (or 0x40040000 - 0x4005_FFFF)	0x1FC4_0000 - 0x1FC5_FFFF	0x0001_0000 - 0x0005_FFFF
Block-3	0x1FC6_0000 - 0x1FC7_FFFF (or 0x4006_0000 - 0x4007_FFFF)	0x1FC6_0000 - 0x1FC7_FFFF	0x0001_8000 - 0x0007_FFFF
Block-4	0x1FC8_0000 - 0x1FC9_FFFF (or 0x4008_0000 - 0x4009_FFFF)	0x1FC8_0000 - 0x1FC9_FFFF	0x0002_0000 - 0x0009_FFFF
Block-5	0x1FCA_0000 - 0x1FCB_FFFF (or 0x400A_0000 - 0x400B_FFFF)	0x1FCA_0000 - 0x1FCB_FFFF	0x0002_8000 - 0x000A_FFFF
Block-6	0x1FCC_0000 - 0x1FCD_FFFF (or 0x400C_0000 - 0x400D_FFFF)	0x1FCC_0000 - 0x1FCD_FFFF	0x0003_0000 - 0x000B_FFFF
Block-7	0x1FCE_0000 - 0x1FCF_FFFF (or 0x400E_0000 - 0x400F_FFFF)	0x1FCE_0000 - 0x1FCF_FFFF	0x0003_8000 - 0x000C_FFFF

3.3.4 Interleave Mode

If J3 (PJ3) is sampled high at the rising edge of $\overline{\text{RESET}}$, the flash memory enters Interleave mode. The flash memory must be configured into Interleave mode.

3.3.5 Block Protection

The TMP1962F10AXBG flash memory is organized into a total of 8 blocks (128 kbyte× 8). To protect stored data from any program and erase operations, each block has a protect bit, which can be set by executing the Block Protect command sequence. Blocks in protection mode are protected from even the Chip Erase and Multi-Block Erase commands; these commands erase only unprotected blocks. Since protection status is stored in flash memory cells, it is retained if the chip is powered off. When all blocks are protected, the data stored in these blocks are protected from being read in Programmer mode, which provides a security feature.

3.3.6 DSU-probe Interface

The DSU-probe interface is used for software debugging using an external DSU-probe unit. This serves as an interface to the DSU-probe, and can not be used as general-purpose port. Consult the DSU-probe operation manual for a description of debugging using the DSU-probe. When the TMP1962F10AXBG is in DSU mode, the on-chip flash memory provides a security feature.

(1) Flash security feature

The TMP1962F10AXBG supports on-board debugging while it is installed on a printed circuit board. The TMP1962F10AXBG provides a security feature to prevent intrusive access to the flash memory. When the flash memory is in the secure state, a DSU-probe is denied access to the entirety of the flash memory.

(2) Securing the flash (Disabling debugging with a DSU-probe)

Once program debug is completed, write the Protect command to all of 8 blocks. This turns on the flash security feature. While the flash memory is in the secure state, a DSU-probe can not read its contents. When the chip is powered off and powered on again, the flash memory is secured, which disables debugging using a DSU-probe until the flash memory is unsecured.

(3) Unsecuring the flash (Enabling debugging with a DSU-probe)

The flash memory may only be unsecured by clearing the SEQON bit in the SEQMOD register and then writing a special code (0x0000_00C5) to the Security Control (SEQCNT) register. This prevents runaway software from inadvertently turning off the security feature. Unsecuring the flash memory enables the DSU interface. The flash memory can be secured again by setting the SEQON bit in the SEQMOD and writing 0x0000_00C5 to the SEQCNT while the chip is powered.

		7	6	5	4	3	2	1	0
SEQMOD (0xFFFF_E510)	Name	—	—	—	—	—	—	—	SEQON
	Read/Write	—	—	—	—	—	—	—	R/W
	Reset Value	—	—	—	—	—	—	—	1
	Function								1: Security on 0: Security off

Note: This register must be read as a 32-bit quantity. Bits 1 to 31 are read as 0s.

	7	6	5	4	3	2	1	0
SEQCNT (0xFFFF_E514)	Name							
	Read/Write							
	Reset Value							
	Function							
	15	14	13	12	11	10	9	8
	Name							
	Read/Write							
	Reset Value							
	Function							
	23	22	21	20	19	18	17	16
	Name							
	Read/Write							
	Reset Value							
	Function							
	31	30	29	28	27	26	25	24
	Name							
	Read/Write							
	Reset Value							
	Function							

Note 1: This register is read as a 32-bit quantity.
Note 2: The security feature of the TMP1962F10AXBG flash memory is not intended to guarantee rigid security protection. In cases where security protection is of utmost importance, use the TMP1962C10BxBG that contains mask ROM.

(4) Application example

The following flowchart exemplifies how to use the security feature with a DSU-ICE.

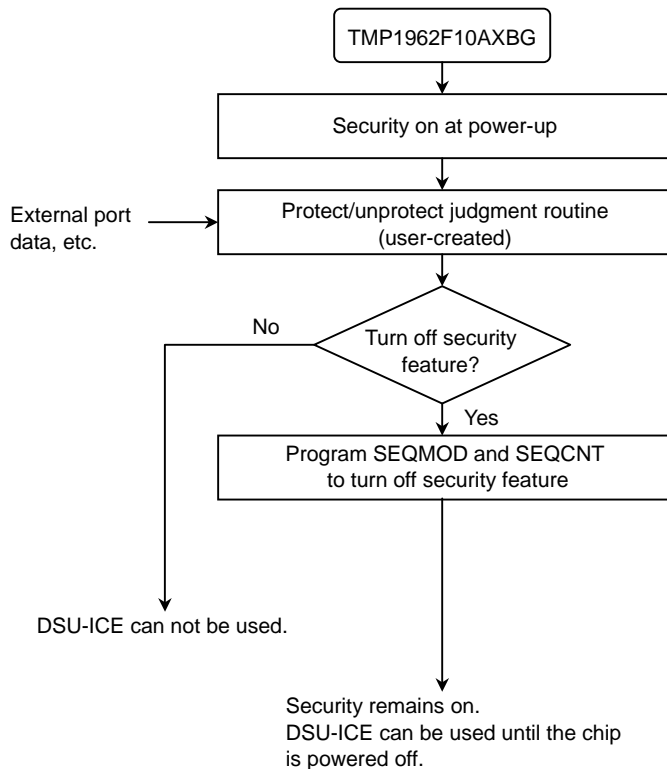

Figure 3.5 Using the Security Feature

3.4 On-Board Programming Mode

On-board programming modes allow

for re-programming of the flash memory while the TMP1962F10AXBG is soldered on a printed circuit board. In Single Boot mode, new data comes from a serial port under control of a Toshiba-provided routine in the boot ROM. User Boot mode allows you to create an algorithm of your own for flash memory erase and program operations.

The TMP1962F10AXBG flash memory provides a security feature to prevent intrusive access to the flash memory while in Programmer mode. This security feature can be enabled upon completion of on-board programming to reduce the potential risk of software leaks to third parties.

3.4.1 User Boot Mode (Single-Chip Mode)

User Boot mode allows you to create a programming algorithm of your own. This mode supports situations where the flash memory is to be re-programmed via a bus other than serial I/O. User Boot mode is one of the two submodes in Single-Chip mode; the other submode is Normal mode in which the CPU executes the user application. To re-program the flash memory, the mode of operation must be switched from Normal mode to User Boot mode. The user application code must include a mode judgment routine as part of the reset procedure.

The user must define the conditions for mode switching, based on the logic states on I/O ports of the TMP1962F10AXBG. Additionally, the user must incorporate a programming algorithm into the user application code that is to be executed after User Boot mode is entered.

It is not possible to read from the flash memory while it is being erased or programmed; therefore, the programming algorithm must be placed and executed outside of the flash memory.

Once re-programming is complete, it is recommended to protect relevant flash blocks from accidental corruption.

All interrupts including the nonmaskable (NMI) interrupt must be globally disabled while the flash memory is being erased or programmed.

The pages that follow describe the general procedures for two cases where the programming routine is: a) stored within the TMP1962F10AXBG flash memory, and b) loaded from an external controller. For a detailed description of the erase and program sequence, refer to Section 3.6, *On-Board Programming and Erasure*.

User Boot Mode

(1-A) Method 1: Storing a Programming Routine in the Flash Memory

- (1) Determine the conditions (e.g., pin states) required for the flash memory to enter User Boot mode and the I/O bus to be used to transfer new program code. Create hardware and software accordingly. Before installing the TMP1962F10AXBG on a printed circuit board, write the following program routines into an arbitrary flash block using programming equipment.
 - Mode judgment routine: Code to determine whether or not to switch to User Boot mode
 - Programming routine: Code to download new program code from a host controller and re-program the flash memory
 - Copy routine: Code to copy the flash programming routine from the TMP1962F10AXBG flash memory to either the TMP1962F10AXBG on-chip RAM or external memory device.

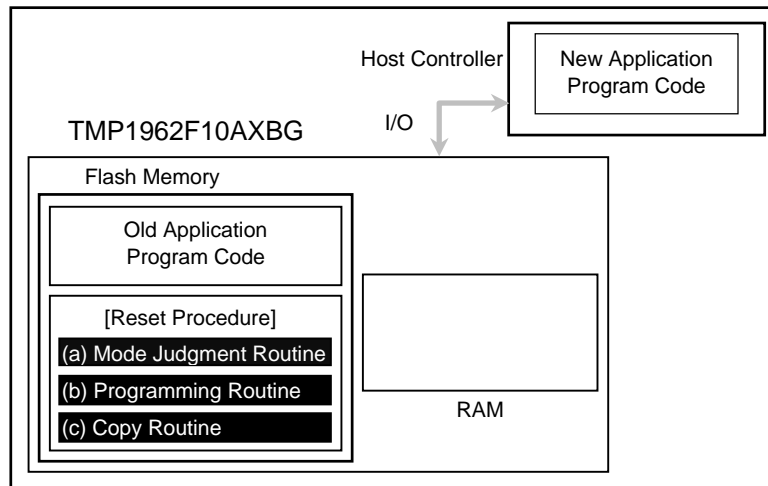

- (2) After $\overline{\text{RESET}}$ is released, the reset procedure determines whether to put the TMP1962F10AXBG flash memory in User Boot mode. If mode switching conditions are met, the flash memory enters User Boot mode. (All interrupts including NMI must be globally disabled while in User Boot mode.)

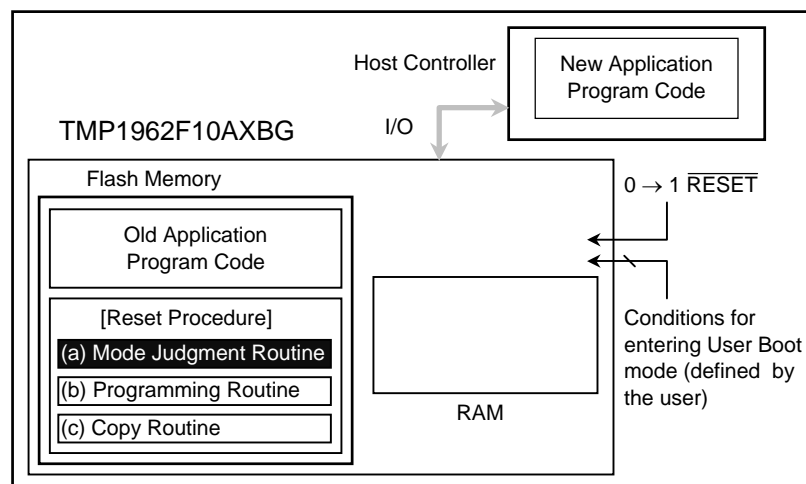

- (3) Once User Boot mode is entered, execute the copy routine to copy the flash programming routine to either the TMP1962F10AXBG on-chip RAM or an external memory device. (In the following figure, the on-chip RAM is used.)

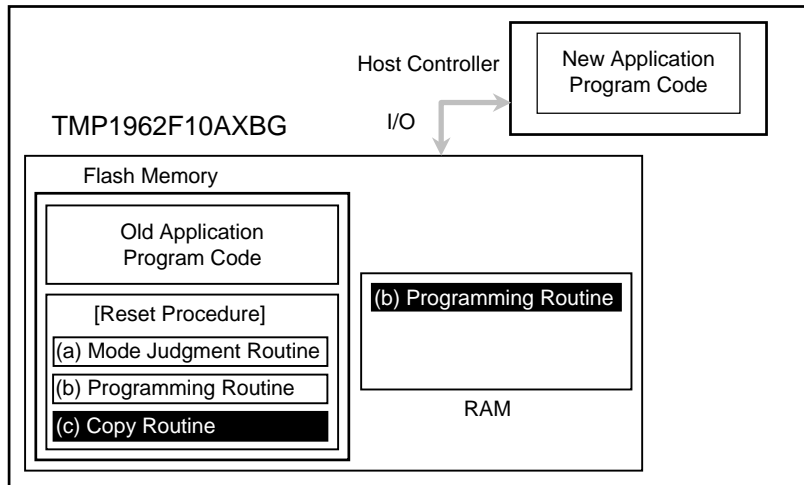

- (4) Jump program execution to the flash programming routine in the on-chip RAM to erase a flash block containing the old application program code.

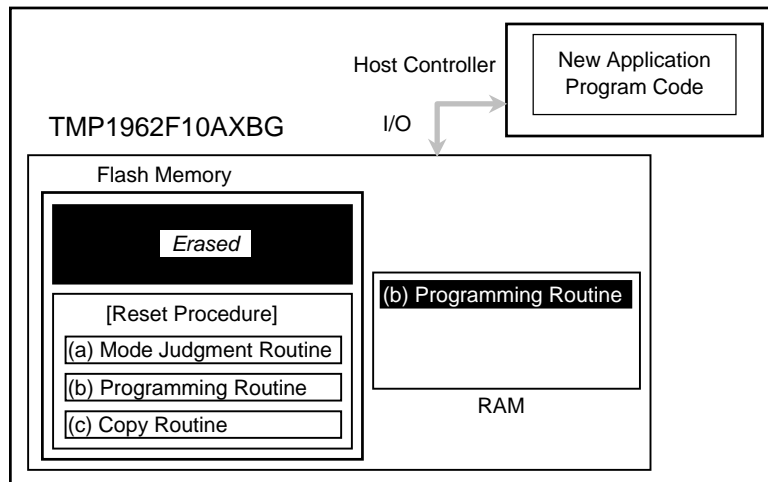

- (5) Continue executing the flash programming routine to download new program code from the host controller and program it into the erased flash block. Once programming is complete, turn on the protection of that flash block.

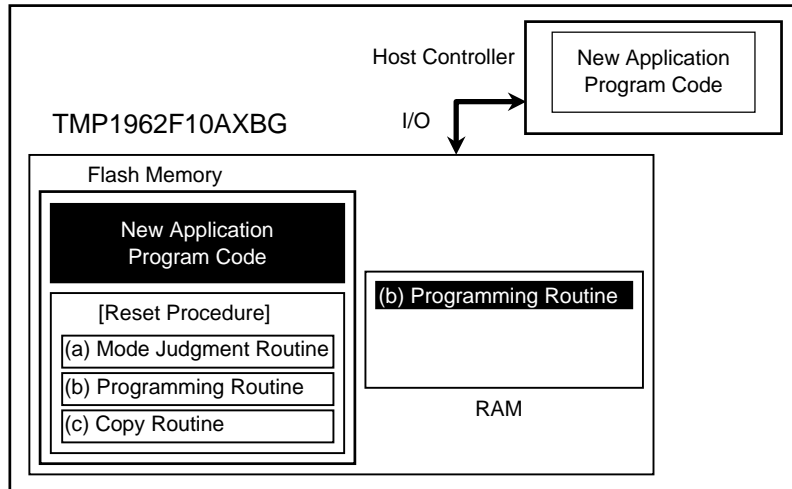

- (6) Drive $\overline{\text{RESET}}$ low to reset the TMP1962F10AXBG. Upon reset, the on-chip flash memory is put in Normal mode. After $\overline{\text{RESET}}$ is released, the CPU will start executing the new application program code.

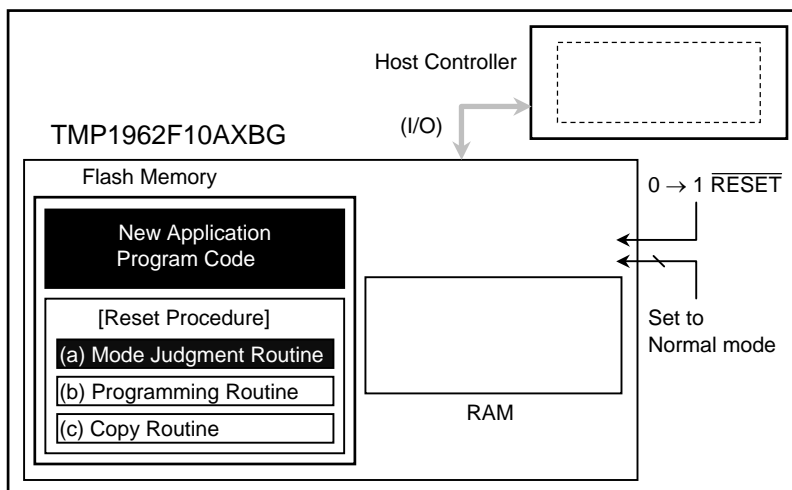

(1-B) Method 2: Transferring a Programming Routine from an External Host

(1) Determine the conditions (e.g., pin states) required for the flash memory to enter User Boot mode and the I/O bus to be used to transfer new program code. Create hardware and software accordingly. Before installing the TMP1962F10AXBG on a printed circuit board, write the following program routines into an arbitrary flash block using programming equipment.

- Mode judgment routine: Code to determine whether or not to switch to User Boot mode
- Transfer routine: Code to download new program code from a host controller

Also, prepare a programming routine on the host controller:

- Programming routine: Code to download new program code from an external host controller and re-program the flash memory

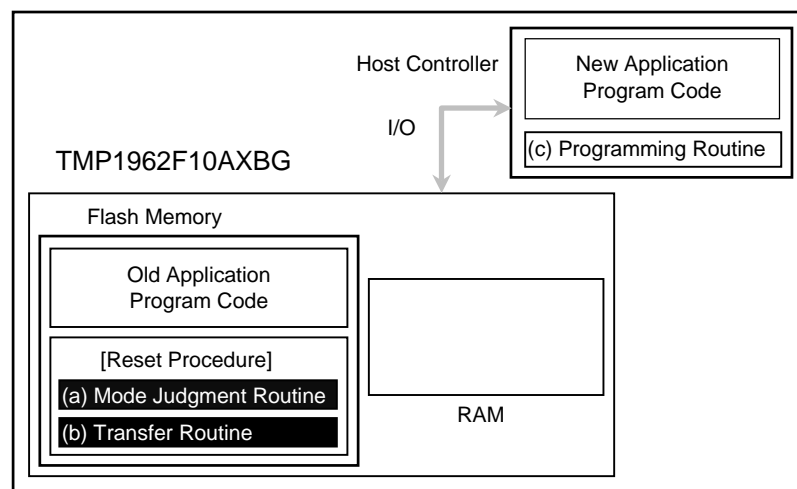

(2) After $\overline{\text{RESET}}$ is released, the reset procedure determines whether to put the TMP1962F10AXBG flash memory in User Boot mode. If mode switching conditions are met, the flash memory enters User Boot mode. (All interrupts including NMI must be globally disabled while in User Boot mode.)

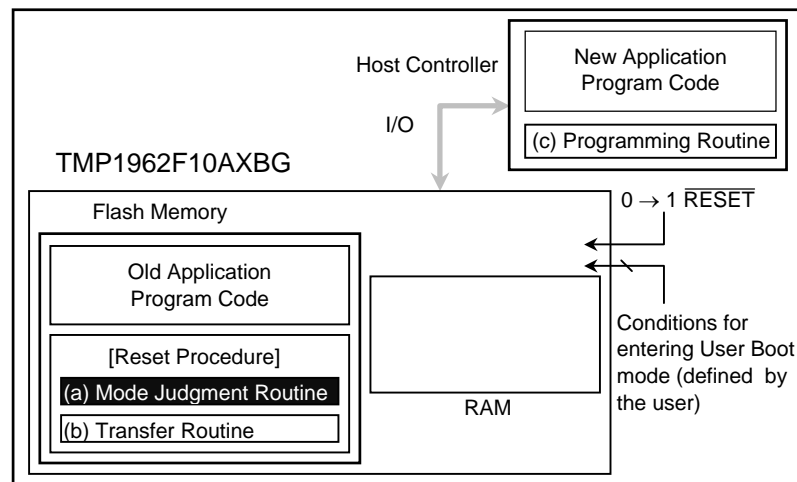

- (3) Once User Boot mode is entered, execute the transfer routine to download the flash programming routine from the host controller to either the TMP1962F10AXBG on-chip RAM or an external memory device. (In the following figure, the on-chip RAM is used.)

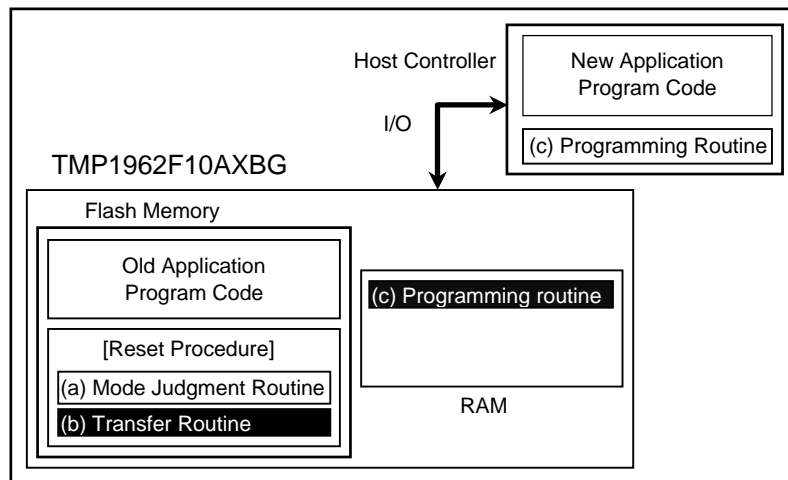

- (4) Jump program execution to the flash programming routine in the on-chip RAM to erase a flash block containing the old application program code.

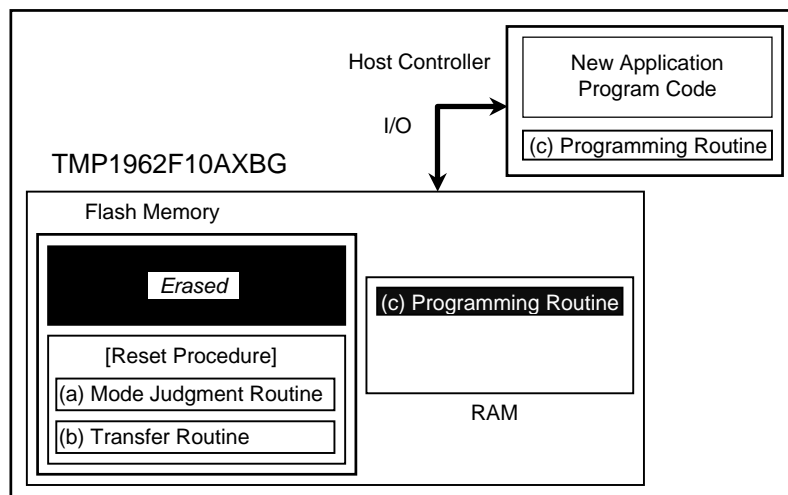

- (5) Continue executing the flash programming routine to download new program code from the host controller and program it into the erased flash block. Once programming is complete, turn on the protection of that flash block.

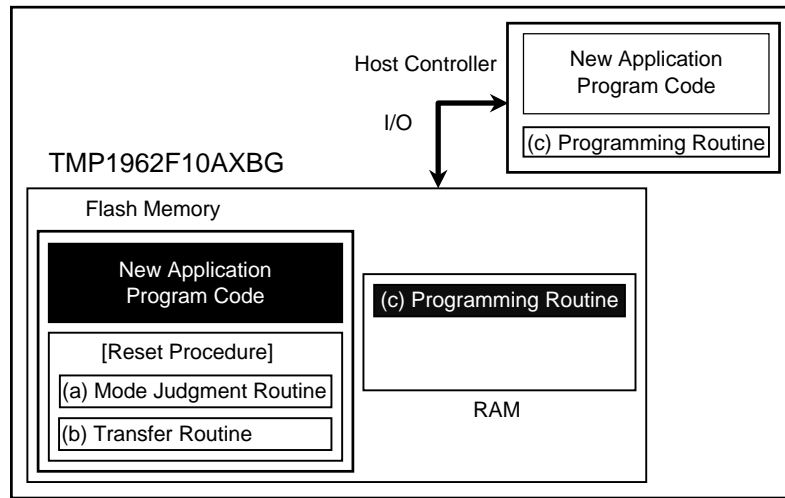

- (6) Drive $\overline{\text{RESET}}$ low to reset the TMP1962F10AXBG. Upon reset, the on-chip flash memory is put in Normal mode. After $\overline{\text{RESET}}$ is released, the CPU will start executing the new application program code.

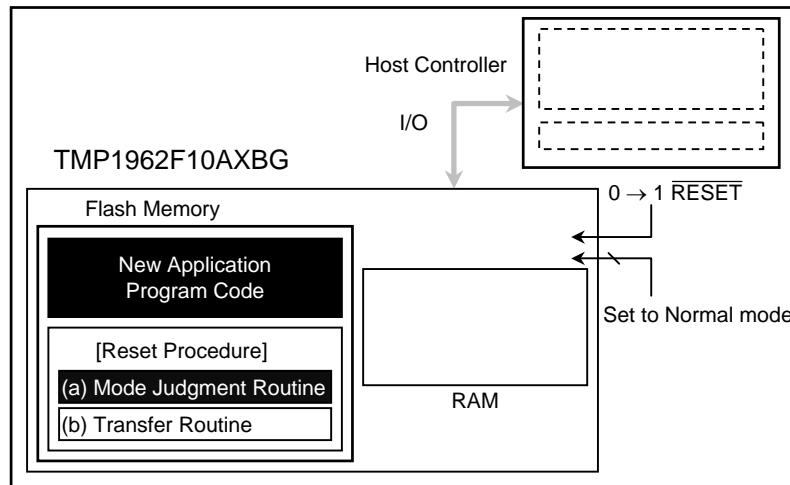

3.5 Single Boot Mode

In Single Boot mode, the flash memory can be re-programmed by using a program contained in the TMP1962F10AXBG on-chip boot ROM. This boot ROM is a masked ROM. When Single Boot mode is selected upon reset, the boot ROM is mapped to the address region including the interrupt vector table while the flash memory is mapped to an address region different from it (see Figure 3.3 on page 19).

Single Boot mode allows for serial programming of the flash memory. Channel 0 of the SIO (SIO0) of the TMP1962F10AXBG is connected to an external host controller. Via this serial link, a programming routine is downloaded from the host controller to the TMP1962F10AXBG on-chip RAM. Then, the flash memory is re-programmed by executing the programming routine. The host sends out both commands and programming data to re-program the flash memory.

Communications between the SIO0 and the host must follow the protocol described later. To secure the contents of the flash memory, the validity of the application's password is checked before a programming routine is downloaded into the on-chip RAM. If password matching fails, the transfer of a programming routine itself is aborted.

As in the case of User Boot mode, all interrupts including the nonmaskable (NMI) interrupt must be globally disabled in Single Boot mode while the flash memory is being erased or programmed. In Single Boot mode, the boot-ROM programs are executed in Normal mode.

Once re-programming is complete, it is recommended to protect relevant flash blocks from accidental corruption during subsequent Single-Chip (Normal mode) operations. For a detailed description of the erase and program sequence, refer to 3.4 On-Board Programming and Erasure.

Boot Mode

(2-A) General Procedure: Using the Program in the On-Chip Boot ROM

- (1) The flash block containing the older version of the program code need not be erased before executing the programming routine. Since a programming routine and programming data are transferred via the SIO0, the SIO0 must be connected to a host controller. Prepare a programming routine on the host controller.

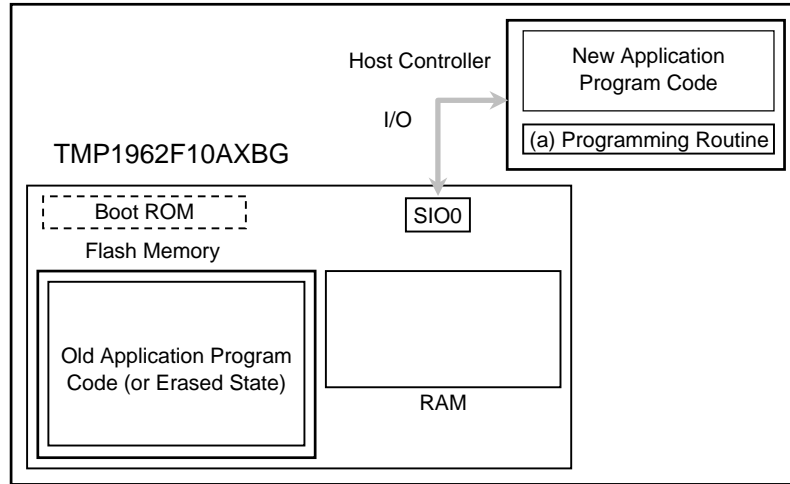

- (2) Reset the TMP1962F10AXBG with the mode setting pins held at appropriate logic values, so that the CPU re-boots from the on-chip boot ROM. The 12-byte password transferred from the host controller is first compared to the contents of special flash memory locations. (If the flash block has already been erased, the password is 0xFFFF.)

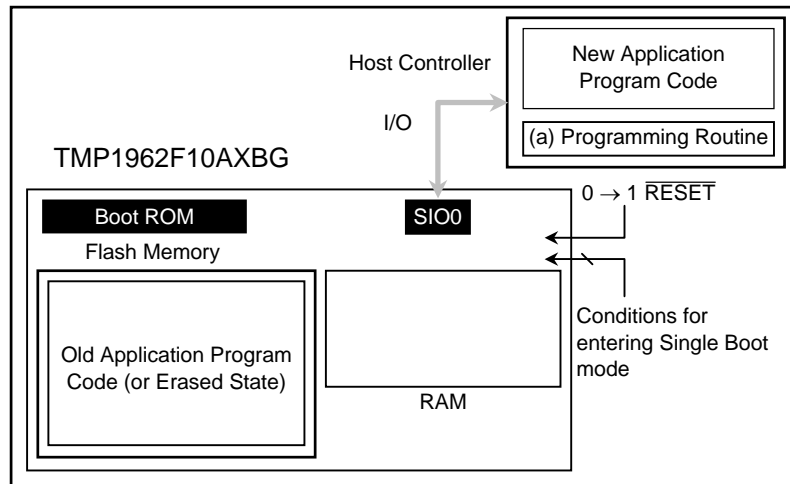

- (3) If the password was correct, the boot program downloads, via the SIO0, the programming routine from the host controller into the on-chip RAM of the TMP1962F10AXBG. The programming routine must be stored in the address range 0xFFFFD_6000 – 0xFFFFD_EFFF.

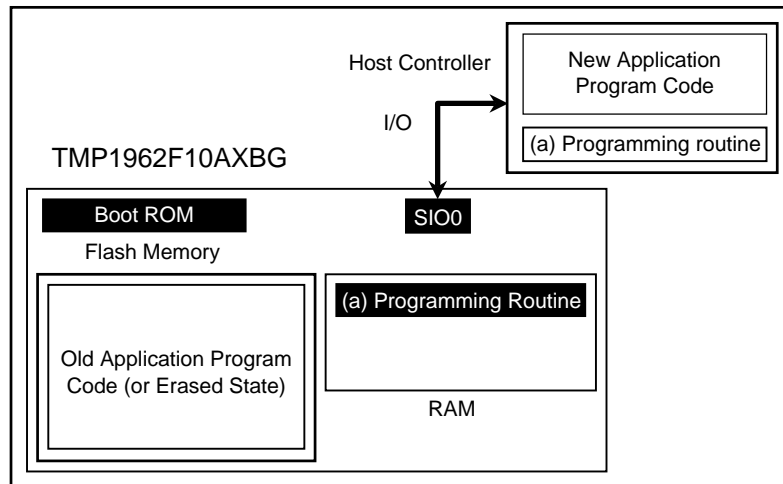

- (4) The CPU jumps to the programming routine in the on-chip RAM to erase the flash block containing the old application program code. The Block Erase or Chip Erase command may be used.

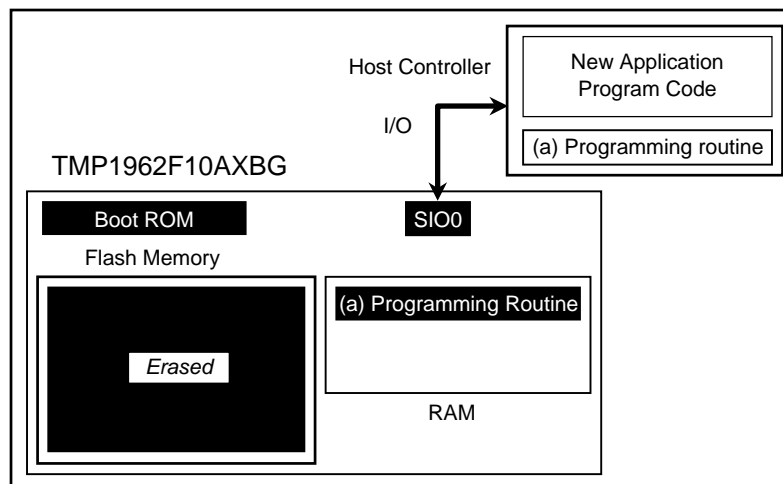

- (5) Next, the programming routine downloads new application program code from the host controller and programs it into the erased flash block. Once programming is complete, protection of that flash block is turned on.

It is not allowed to move program control from the programming routine back to the boot ROM.

In the example below, new program code comes from the same host controller via the same SIO channel as for the programming routine. However, once the programming routine has begun to execute, it is free to change the transfer path and the source of the transfer. Create board hardware and a programming routine to suit your particular needs.

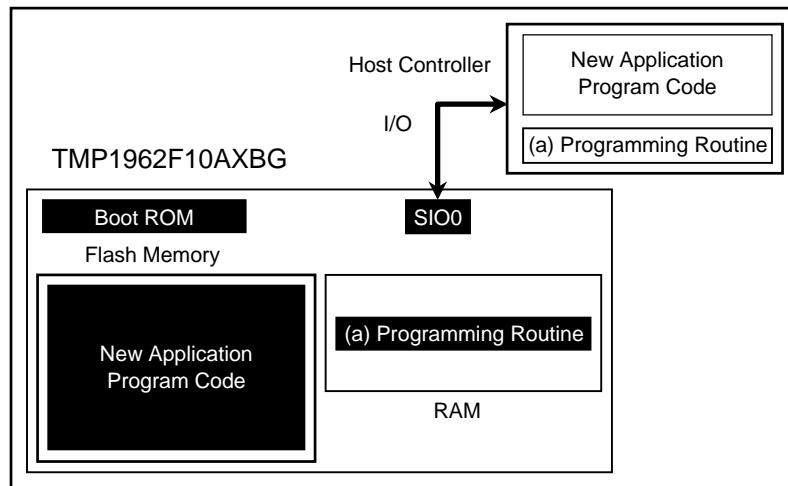

- (6) When programming of the flash memory is complete, power off the board and disconnect the cable leading from the host to the target board. Turn on the power again so that the TMP1962F10AXBG re-boots in Single-Chip (Normal) mode to execute the new program.

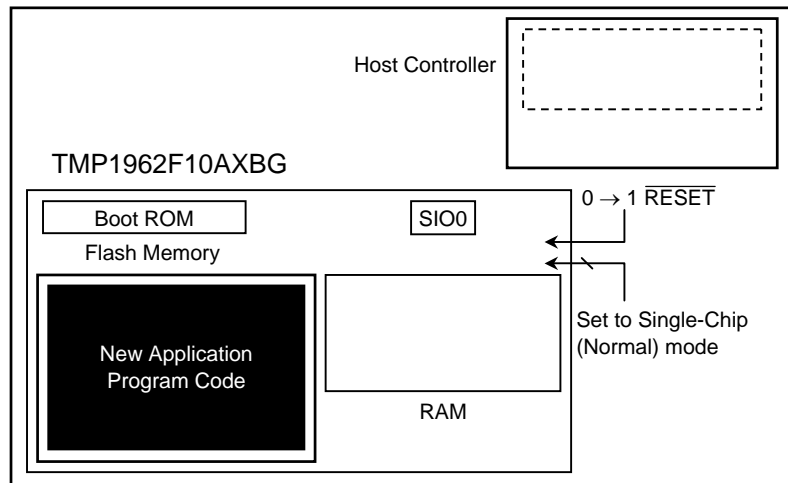

3.5.1 Host-to-Target Connection Examples

In Single Boot mode, serial transfer is used to re-program the flash memory while the TMP1962F10AXBG is installed on the board. In this mode, channel 0 of the SIO (SIO0) of the TMP1962F10AXBG is connected to a host controller, which is to issue commands to the target board. Figure 3.6 and Figure 3.7 show examples of host-to-target connections.

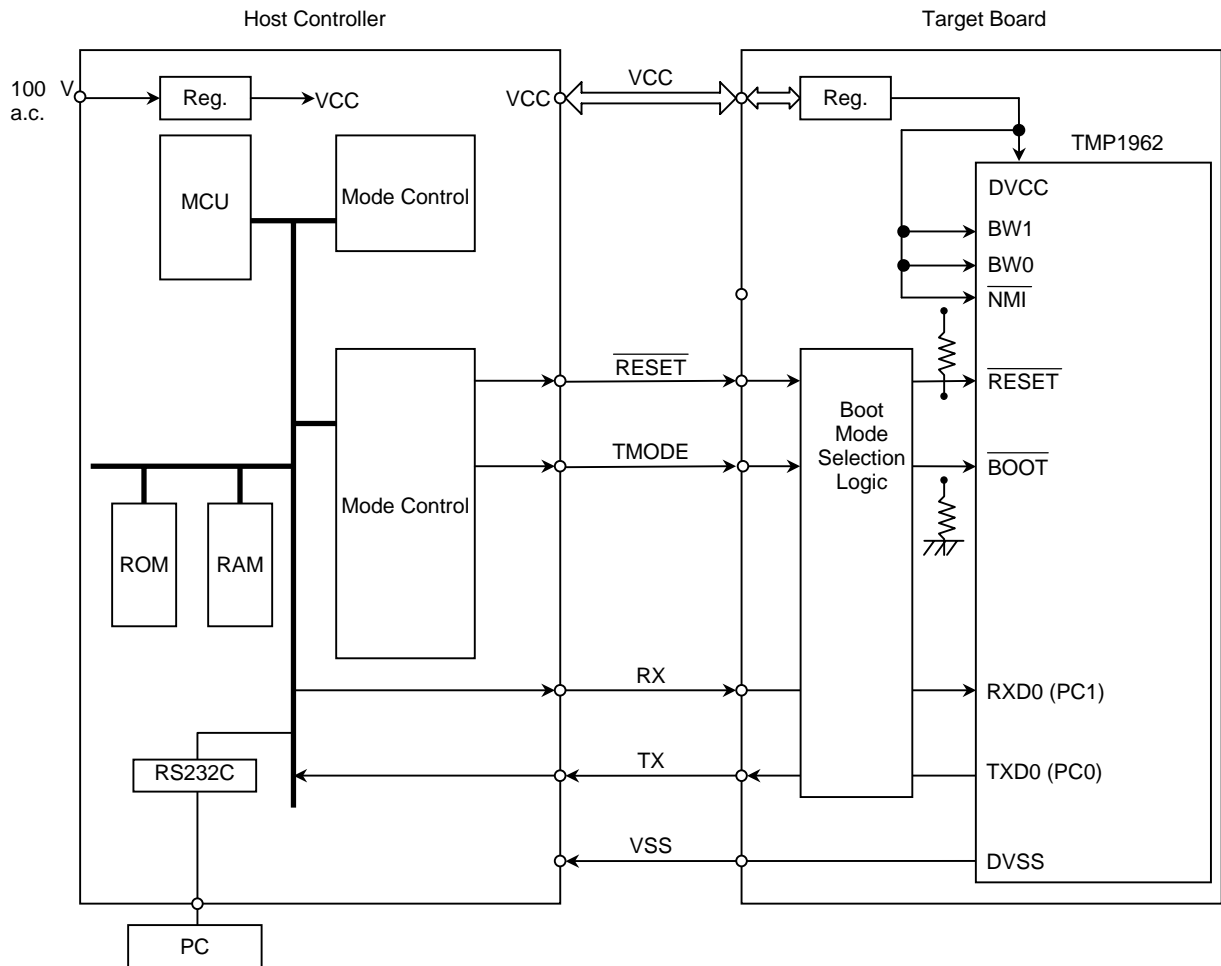

Figure 3.6 Example of a Connection Between a Host Controller and a Target Board
(When the SIO0 is Configured for UART Mode)

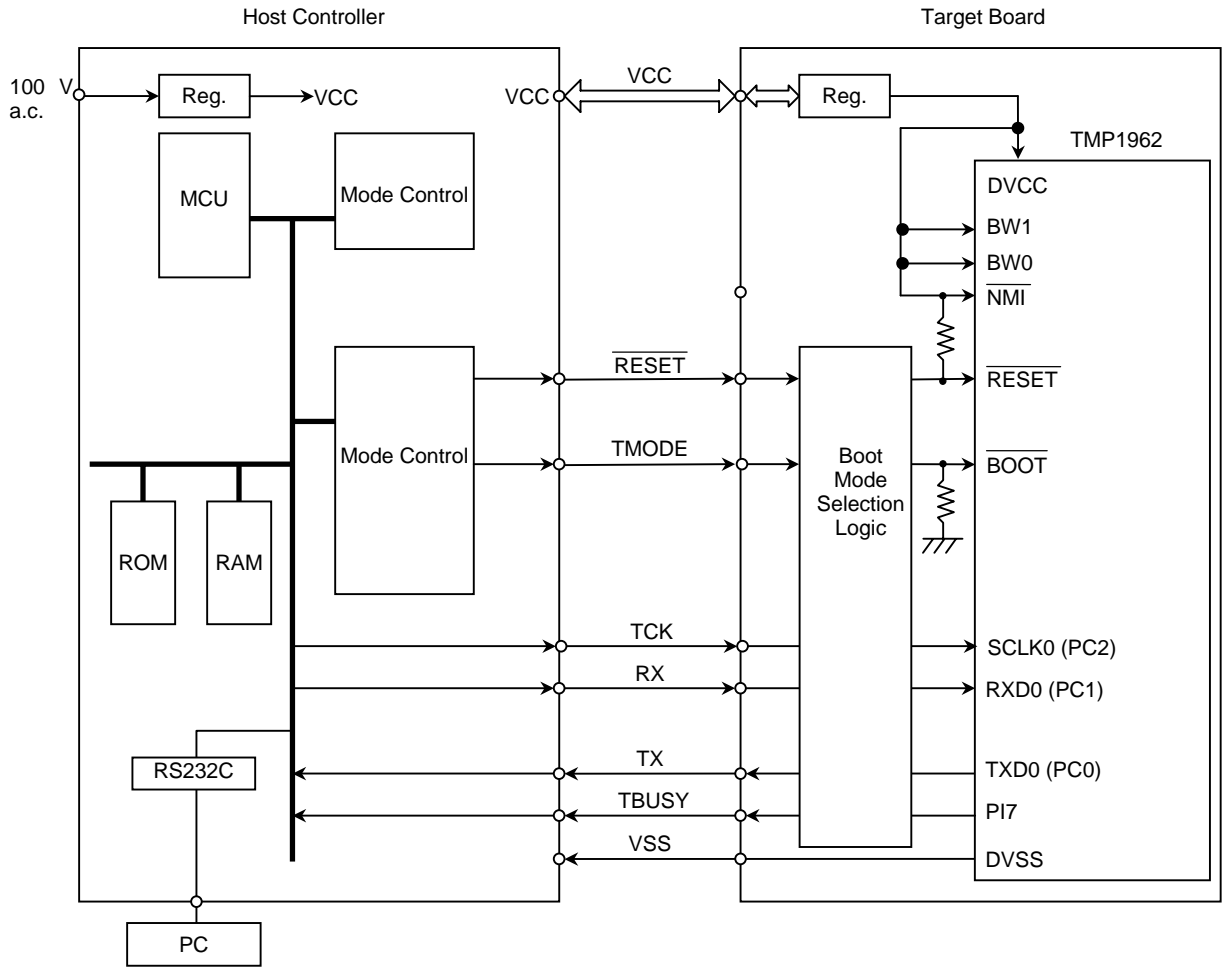

Figure 3.7 Example of a Connection Between a Host Controller and a Target Board
(When the SIO0 is Configured for I/O Interface Mode)

3.5.2 Configuring for Single Boot Mode

For on-board programming, boot the TMP1962F10AXBG in Single Boot mode, as follows:

- BW0 = 1
- BW1 = 1
- $\overline{\text{BOOT}}$ = 0
- $\overline{\text{RESET}}$ = 0 → 1

Set the $\overline{\text{RESET}}$ input at logic 0, and the BW0, BW1 and $\overline{\text{BOOT}}$ (PJ2) inputs at the logic values shown above, and then release $\overline{\text{RESET}}$ (high).

3.5.3 Memory Map

Figure 3.8 shows a comparison of the memory maps in Normal and Single Boot modes. In single Boot mode, the on-chip flash memory is mapped to physical addresses (0x4000_0000 through 0x400F_FFFF), virtual addresses (0x0000_0000 through 0x000F_FFFF), and the on-chip boot ROM is mapped to physical addresses 0x1FC0_0000 through 0x1FC0_1FFF.

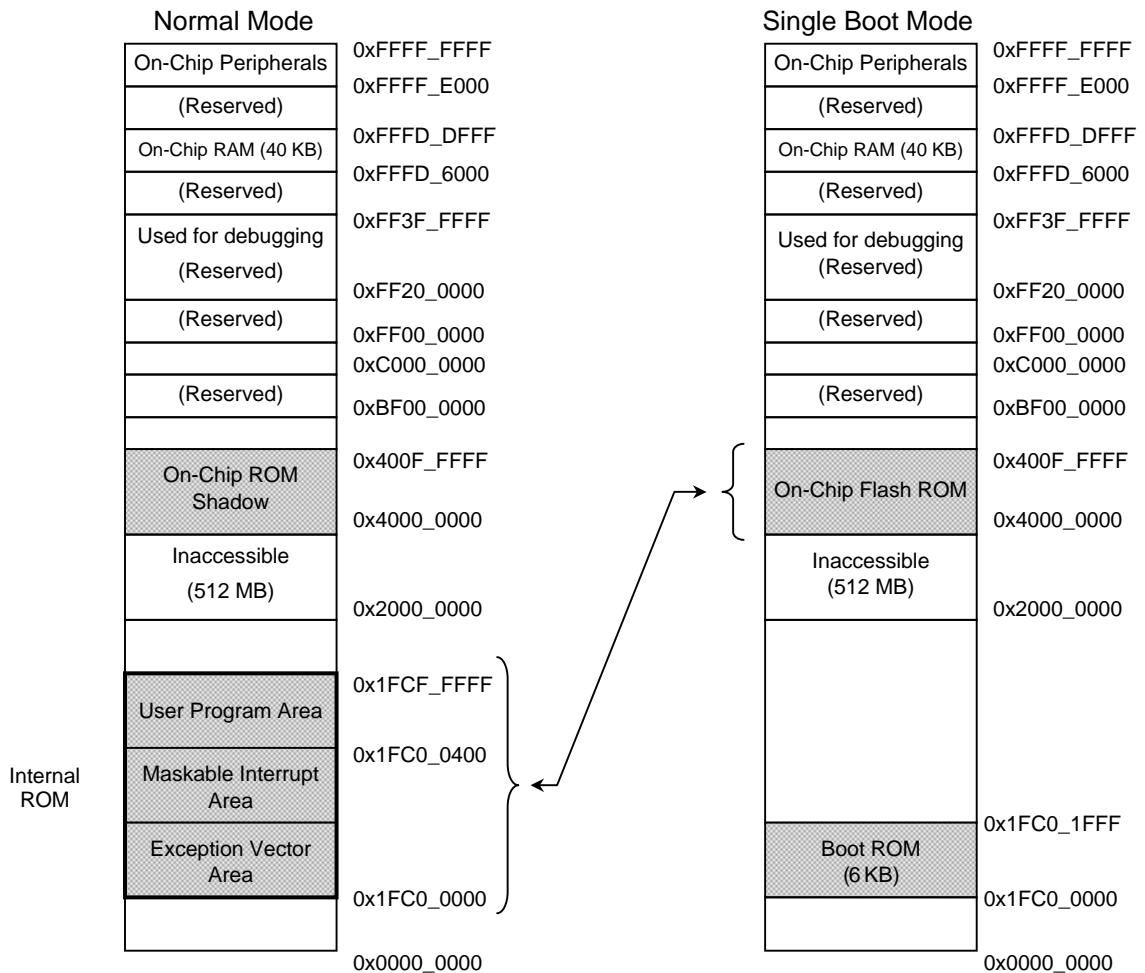

Figure 3.8 Memory Maps for Normal and Single Boot Modes (Physical Addresses)

3.5.4 Interface Specification

In Single Boot mode, an SIO channel is used for communications with a programming controller. Both UART (asynchronous) and I/O Interface (synchronous) modes are supported. The communication formats are shown below. In the subsections that follow, virtual addresses are indicated, unless otherwise noted.

- UART mode
 - Communication channel: SIO Channel 0 (SIO0)
 - Transfer mode: UART (asynchronous) mode, full-duplex
 - Data length: 8 bits
 - Parity bits: None
 - STOP bits: 1
 - Baud rate: Arbitrary baud rate

- I/O Interface mode
 - Communication channel: SIO Channel 0 (SIO0)
 - Transfer mode: I/O Interface mode, half-duplex
 - Synchronization clock (SCLK0): Input
 - Handshaking signal: PI7 configured as an output
 - Baud rate: Arbitrary baud rate

Table 3.4 Required Pin Connections

Pin		Interface	
		UART Mode	I/O Interface Mode
Power Supply Pins	DVCC2 (2.5 V)	Required	Required
	DVSS	Required	Required
Mode-Setting Pin	$\overline{\text{BOOT}}$	Required	Required
Reset Pin	$\overline{\text{RESET}}$	Required	Required
Communication Pins	TXD0	Required	Required
	RXD0	Required	Required
	SCLK0	Not Required	Required (Input Mode)
	P87	Not Required	Required (Input Mode)

3.5.5 Data Transfer Format

The host controller is to issue one of the commands listed in Table 3.5 to the target board. Table 3.6 to Table 3.8 illustrate the sequence of two-way communications that should occur in response to each command.

Table 3.5 Single Boot Mode Commands

Code	Command
10H	RAM Transfer
20H	Show Flash Memory Sum
30H	Show Product Information

Table 3.6 Transfer Format for the RAM Transfer Command

	Byte	Data Transferred from the Controller to the TMP1962F10AXBG	Baud Rate	Data Transferred from the TMP1962F10AXBG to the Controller	
Boot ROM	1st byte	Serial operation mode and baud rate For UART mode 86H For I/O Interface mode 30H	Desired baud rate (Note 1)	—	
	2nd byte	—		ACK for the serial operation mode byte For UART mode Normal acknowledge 86H (The boot program aborts if the baud rate is can not be set correctly.) For I/O Interface mode Normal acknowledge 30H	
	3rd byte	Command code (10H)		—	
	4th byte	—		ACK for the command code byte (Note 2) Normal acknowledge 10H Negative acknowledge x1H Communication error x8H	
	5th byte thru 16th byte	Password sequence (12 bytes) (0x4000_03F4 thru 0x4000_03FF)		—	
	17th byte	Checksum value for bytes 5–16		—	
	18th byte	—		ACK for the checksum byte (Note 2) Normal acknowledge 10H Negative acknowledge 11H Communication error 18H	
	19th byte	RAM storage start address (bits 31–24)		—	
	20th byte	RAM storage start address (bits 23–16)		—	
	21st byte	RAM storage start address (bits 15–8)		—	
	22nd byte	RAM storage start address (bits 7–0)		—	
	23rd byte	RAM storage byte count (bits 15–8)		—	
	24th byte	RAM storage byte count (bits 7–0)		—	
	25th byte	Checksum value for bytes 19–24		—	
	26th byte	—		ACK for the checksum byte (Note 2) Normal acknowledge 10H Negative acknowledge 11H Communication error 18H	
	27th byte thru mth byte	RAM storage data		—	
	(m + 1)th byte	Checksum value for bytes 27–m		—	
	(m + 2)th byte	—		ACK for the checksum byte (Note 2) Normal acknowledge 10H Non-acknowledge 11H Communications error 18H	
	RAM	(m + 3)th byte		—	Jump to RAM storage start address

Note 1: In I/O Interface mode, the baud rate for the transfers of the first and second bytes must be 1/16 of the desired baud rate.

Note 2: In case of any negative acknowledge, the boot program returns to a state in which it waits for a command code (3rd byte). In I/O Interface mode, if a communication error occurs, a negative acknowledge does not occur.

Note 3: The 19th to 25th bytes must be within the RAM address range 0xFFFFD_6000–0xFFFF_DFFF

Table 3.7 Transfer Format for the Show Flash Memory Sum Command

	Byte	Data Transferred from the Controller to the TMP1962F10AXBG	Baud Rate	Data Transferred from the TMP1962F10AXBG to the Controller
Boot ROM	1st byte	Serial operation mode and baud rate For UART mode 86H For I/O Interface mode 30H	Desired baud rate (Note 1)	—
	2nd byte	—		ACK for the serial operation mode byte For UART mode Normal acknowledge 86H (The boot program aborts if the baud rate can not be set correctly.) For I/O Interface mode Normal acknowledge 30H
	3rd byte	Command code (20H)		—
	4th byte	—		ACK for the command code byte (Note 2) Normal acknowledge 20H Negative acknowledge x1H Communication error x8H
	5th byte	—		SUM (upper byte)
	6th byte	—		SUM (lower byte)
	7th byte	—		Checksum value for bytes 5 and 6
	8th byte	(Wait for the next command code.)		—

Note 1: In I/O Interface mode, the baud rate for the transfers of the first and second bytes must be 1/16 of the desired baud rate.

Note 2: In case of any negative acknowledge, the boot program returns to a state in which it waits for a command code (3rd byte). In I/O Interface mode, if a communication error occurs, a negative acknowledge does not occur.

Table 3.8 Transfer Format for the Show Product Information Command (1/2)

	Byte	Data Transferred from the Controller to the TMP1962F10AXBG	Baud Rate	Data Transferred from the TMP1962F10AXBG to the Controller
Boot ROM	1st byte	Serial operation mode and baud rate For UART mode 86H For I/O Interface mode 30H	Desired baud rate (Note 1)	—
	2nd byte	—		ACK for the serial operation mode byte For UART mode Normal acknowledge 86H (The boot program aborts if the baud rate can not be set correctly.) For I/O Interface mode Normal acknowledge 30H
	3rd byte	Command code (30H)		—
	4th byte	—		ACK for the command code byte (Note 2) Normal acknowledge 10H Negative acknowledge x1H Communication error x8H
	5th byte	—		Flash memory data (at address 0x4000_03F0H)
	6th byte	—		Flash memory data (at address 0x4000_03F1H)
	7th byte	—		Flash memory data (at address 0x4000_03F2H)
	8th byte	—		Flash memory data (at address 0x4000_03F3H)
	9th byte thru 20th byte	—		Product name (12-byte ASCII code) "TX1962F10" from the 9th byte
	21st byte thru 24th byte	—		Password comparison start address (4 bytes) F4H, 03H, 00H and 00H from the 21st byte
	25th byte thru 28th byte	—		RAM start address (4 bytes) 00H, 60H, FDH and FFH from the 25th byte
	29th byte thru 32nd byte	—		Dummy data (4 bytes) FFH, 6FH, FDH and FFH from the 29th byte
	33rd byte thru 36th byte	—		RAM end address (4 bytes) FFH, DFH, FDH and FFH from the 33rd byte
	37th byte thru 40th byte	—		Dummy data (4 bytes) 00H, 70H, FDH and FFH from the 37th byte
	41st byte thru 44th byte	—		Dummy data (4 bytes) FFH, EFH, FDH and FFH from the 41st byte
	45th byte thru 46th byte	—		Fuse information (2 bytes) 01H and 00H from the 45th byte
	47th byte thru 50th byte	—		Flash memory start address (4 bytes) 00H, 00H, 00H and 00H from the 47th byte
	51st byte thru 54th byte	—		Flash memory end address (4 bytes) FFH, FFH, 0FH and 00H from the 51st byte
	55th byte thru 56th byte	—		Flash memory block count (2 bytes) 08H and 00H from at the 55th byte

Table 3.8 Transfer Format for the Show Product Information Command (2/2)

	Byte	Data Transferred from the Controller to the TMP1962F10AXBG	Baud Rate	Data Transferred from the TMP1962F10AXBG to the Controller
Boot ROM	57th byte thru 60th byte	—		Start address of a group of the same-size flash blocks (4 bytes) 00H, 00H, 00H and 00H from the 57th byte
	61st byte thru 64th byte	—		Size (in halfwords) of the same-size flash blocks (4 bytes) 00H, 00H, 01H and 00H from the 61st byte
	65th byte	—		Number of flash blocks of the same size (1 byte) 08H
	66th byte	—		Checksum value for bytes 5 to 65
	67th byte	(Wait for the next command code.)		—

Note 1: In I/O Interface mode, the baud rate for the transfers of the first and second bytes must be 1/16 of the desired baud rate.

Note 2: In case of any negative acknowledge, the boot program returns to a state in which it waits for a command code (3rd byte). In I/O Interface mode, if a communication error occurs, a negative acknowledge does not occur.

3.5.6 Overview of the Boot Program Commands

When Single Boot mode is selected, the boot program is automatically executed on startup. The boot program offers these three commands, the details of which are provided on the following subsections.

- RAM Transfer command

The RAM Transfer command stores program code transferred from a host controller to the on-chip RAM and executes the program once the transfer is successfully completed. The maximum program size is 36 kbytes. The RAM storage start address must be within the range.

The RAM Transfer command can be used to download a flash programming routine of your own; this provides the ability to control on-board programming of the flash memory in a unique manner. The programming routine must utilize the flash memory command sequences described in Section 3.6.17

Before initiating a transfer, the RAM Transfer command checks a password sequence coming from the controller against that stored in the flash memory. If they do not match, the RAM Transfer command aborts.

Once the RAM Transfer command is complete, the whole on-chip RAM is accessible.

- Show Flash Memory Sum command

The Show Flash Memory Sum command adds the contents of the 1024 kbytes of the flash memory together. The boot program does not provide a command to read out the contents of the flash memory. Instead, the Flash Memory Sum command can be used for software revision management.

- Show Product Information command

The Show Product Information command provides the product name, on-chip memory configuration and the like. This command also reads out the contents of the flash memory locations at addresses 0x0000_03F0 through 0x0000_03F3. In addition to the Show Flash Memory Sum command, these locations can be used for software revision management.

3.5.7 RAM Transfer Command

See Table 3.6.

- (1) The 1st byte specifies which one of the two serial operation modes is used. For a detailed description of how the serial operation mode is determined, see Section 3.5.11. If it is determined as UART mode, the boot program then checks if the SIO0 is programmable to the baud rate at which the 1st byte was transferred. During the first-byte interval, the RXE bit in the SC0MOD register is cleared.
 - To communicate in UART mode

Send, from the controller to the target board, 86H in UART data format at the desired baud rate. If the serial operation mode is determined as UART, then the boot program checks if the SIO0 can be programmed to the baud rate at which the first byte was transferred. If that baud rate is not possible, the boot program aborts, disabling any subsequent communications.
 - To communicate in I/O Interface mode

Send, from the controller to the target board, 30H in I/O Interface data format at 1/16 of the desired baud rate. Also send the 2nd byte at the same baud rate. Then send all subsequent bytes at a rate equal to the desired baud rate.

In I/O Interface mode, the CPU sees the serial receive pin as if it were a general input port in monitoring its logic transitions. If the baud rate of the incoming data is high or the chip's operating frequency is high, the CPU may not be able to keep up with the speed of logic transitions. To prevent such situations, the 1st and 2nd bytes must be transferred at 1/16 of the desired baud rate; then the boot program calculates 16 times that as the desired baud rate.

When the serial operation mode is determined as I/O Interface mode, the SIO0 is configured for SCLK Input mode. Beginning with the third byte, the controller must ensure that its AC timing restrictions are satisfied at the selected baud rate. In the case of I/O Interface mode, the boot program does not check the receive error flag; thus there is no such thing as error acknowledge (x8H).
- (2) The 2nd byte, transmitted from the target board to the controller, is an acknowledge response to the 1st byte. The boot program echoes back the first byte: 86H for UART mode and 30H for I/O Interface mode.
 - UART mode

If the SIO0 can be programmed to the baud rate at which the 1st byte was transferred, the boot program programs the BR0CR and sends back 86H to the controller as an acknowledge. If the SIO0 is not programmable at that baud rate, the boot program simply aborts with no error indication.

Following the 1st byte, the controller should allow for a time-out period of five seconds. If it does not receive 86H within the allotted time-out period, the controller should give up the communication.

The boot program sets the RXE bit in the SC0MOD register to enable reception before loading the SIO transmit buffer with 86H.

- I/O Interface mode

The boot program programs the SC0MOD0 and SC0CR registers to configure the SIO0 in I/O Interface mode (clocked by the rising edge of SCLK0), writes 30H to the SC0BUF. Then, the SIO0 waits for the SCLK0 signal to come from the controller. Following the transmission of the 1st byte, the controller should send the SCLK clock to the target board after a certain idle time (several microseconds). This must be done at 1/16 the desired baud rate. If the 2nd byte, which is from the target board to the controller, is 30H, then the controller should take it as a go-ahead. The controller must then deliver the 3rd byte to the target board at a rate equal to the desired baud rate. The boot program sets the RXE bit in the SC0MOD register to enable reception before loading the SIO transmit buffer with 30H.

- (3) The 3rd byte, which the target board receives from the controller, is a command. The code for the RAM Transfer command is 10H.
- (4) The 4th byte, transmitted from the target board to the controller, is an acknowledge response to the 3rd byte. Before sending back the acknowledge response, the boot program checks for a receive error. If there was a receive error, the boot program transmits x8H and returns to the state in which it waits for a command again. In this case, the upper four bits of the acknowledge response are undefined — they hold the same values as the upper four bits of the previously issued command. When the SIO0 is configured for I/O Interface mode, the boot program does not check for a receive error.

If the 3rd byte is equal to any of the command codes listed in Table 3.5, the boot program echoes it back to the controller. When the RAM Transfer command was received, the boot program echoes back a value of 10H and then branches to the RAM Transfer routine. Once this branch is taken, a password check is done. Password checking is detailed in Section 3.5.12.

If the 3rd byte is not a valid command, the boot program sends back x1H to the controller and returns to the state in which it waits for a command again. In this case, the upper four bits of the acknowledge response are undefined — they hold the same values as the upper four bits of the previously issued command.

- (5) The 5th to 16th bytes, which the target board receives from the controller, are a 12-byte password. The 5th byte is compared to the contents of address 0x0000_03F4 in the flash memory; the 6th byte is compared to the contents of address 0x0000_03F5 in the flash memory; likewise, the 16th byte is compared to the contents of address 0x0000_03FF in the flash memory. If the password checking fails, the RAM Transfer routine sets the password error flag.
- (6) The 17th byte is a checksum value for the password sequence (5th to 16th bytes). To calculate the checksum value for the 12-byte password, add the 12 bytes together, drop the carries and take the two's complement of the total sum. Transmit this checksum value from the controller to the target board. The checksum calculation is described in details in Section 3.5.14.

- (7) The 18th byte, transmitted from the target board to the controller, is an acknowledge response to the 5th to 17th bytes.

First, the RAM Transfer routine checks for a receive error in the 5th to 17th bytes. If there was a receive error, the boot program sends back 18H and returns to the state in which it waits for a command (i.e., the 3rd byte) again. In this case, the upper four bits of the acknowledge response are the same as those of the previously issued command (i.e., all 1s). When the SIO0 is configured for I/O Interface mode, the RAM Transfer routine does not check for a receive error.

Next, the RAM Transfer routine performs the checksum operation to ensure data integrity. Adding the series of the 5th to 17th bytes must result in zero (with the carry dropped). If it is not zero, one or more bytes of data has been corrupted. In case of a checksum error, the RAM Transfer routine sends back 11H to the controller and returns to the state in which it waits for a command (i.e., the 3rd byte) again.

Finally, the RAM Transfer routine examines the result of the password check. The following two cases are treated as a password error. In these cases, the RAM Transfer routine sends back 11H to the controller and returns to the state in which it waits for a command (i.e., the 3rd byte) again.

- Irrespective of the result of the password comparison, all of the 12 bytes of a password in the flash memory are the same value other than FFH.
- Not all of the password bytes transmitted from the controller matched those contained in the flash memory.

When all the above checks have been successful, the RAM Transfer routine returns a normal acknowledge response (10H) to the controller.

- (8) The 19th to 22nd bytes, which the target board receives from the controller, indicate the start address of the RAM region where subsequent data (e.g., a flash programming routine) should be stored. The 19th byte corresponds to bits 31–24 of the address, and the 22nd byte corresponds to bits 7–0 of the address.
- (9) The 23rd and 24th bytes, which the target board receives from the controller, indicate the number of bytes that will be transferred from the controller to be stored in the RAM. The 23rd byte corresponds to bits 15–8 of the number of bytes to be transferred, and the 24th byte corresponds to bits 7–0 of the number of bytes.
- (10) The 25th byte is a checksum value for the 19th to 24th bytes. To calculate the checksum value, add all these bytes together, drop the carries and take the two's complement of the total sum. Transmit this checksum value from the controller to the target board. The checksum calculation is described in details in Section 3.5.14.
- (11) The 26th byte, transmitted from the target board to the controller, is an acknowledge response to the 19th to 25th bytes of data.

First, the RAM Transfer routine checks for a receive error in the 19th to 25th bytes. If there was a receive error, the RAM Transfer routine sends back 18H and returns to the state in which it waits for a command (i.e., the 3rd byte) again. In this case, the upper four bits of the acknowledge response are the same as those of the previously issued command (i.e., all 1s). When the SIO0 is configured for I/O Interface mode, the RAM Transfer routine does not check for a receive error.

Next, the RAM Transfer routine performs the checksum operation to ensure data integrity. Adding the series of the 19th to 25th bytes must result in zero (with the carry dropped). If it is not zero, one or more bytes of data has been corrupted. In case of a checksum error, the RAM Transfer routine sends back 11H to the controller and returns to the state in which it waits for a command (i.e., the 3rd byte) again.

- The RAM storage start address must be within the range 0xFFFFD_6000–0xFFFFD_EFFF.

When the above checks have been successful, the RAM Transfer routine returns a normal acknowledge response (10H) to the controller.

- (12) The 27th to mth bytes from the controller are stored in the on-chip RAM of the TMP1962F10AXBG. Storage begins at the address specified by the 19th–22nd bytes and continues for the number of bytes specified by the 23rd–24th bytes.
- (13) The (m+1)th byte is a checksum value. To calculate the checksum value, add the 27th to mth bytes together, drop the carries and take the two's complement of the total sum. Transmit this checksum value from the controller to the target board. The checksum calculation is described in details in Section 3.5.14.
- (14) The (m+2)th byte is a acknowledge response to the 27th to (m+1)th bytes.

First, the RAM Transfer routine checks for a receive error in the 27th to (m+1)th bytes. If there was a receive error, the RAM Transfer routine sends back 18H and returns to the state in which it waits for a command (i.e., the 3rd byte) again. In this case, the upper four bits of the acknowledge response are the same as those of the previously issued command (i.e., all 1s). When the SIO0 is configured for I/O Interface mode, the RAM Transfer routine does not check for a receive error.
- (15) Next, the RAM Transfer routine performs the checksum operation to ensure data integrity. Adding the series of the 27th to (m+1)th bytes must result in zero (with the carry dropped). If it is not zero, one or more bytes of data has been corrupted. In case of a checksum error, the RAM Transfer routine sends back 11H to the controller and returns to the state in which it waits for a command (i.e., the 3rd byte) again. When the above checks have been successful, the RAM Transfer routine returns a normal acknowledge response (10H) to the controller. If the (m+2)th byte was a normal acknowledge response, a branch is made to the address specified by the 19th to 22nd bytes in 32-bit ISA mode.

3.5.8 Show Flash Memory Sum Command

See Table 3.7.

- (1) The processing of the 1st and 2nd bytes are the same as for the RAM Transfer command.
- (2) The 3rd byte, which the target board receives from the controller, is a command. The code for the Show Flash Memory Sum command is 20H.
- (3) The 4th byte, transmitted from the target board to the controller, is an acknowledge response to the 3rd byte. Before sending back the acknowledge response, the boot program checks for a receive error. If there was a receive error, the boot program transmits x8H and returns to the state in which it waits for a command again. In this case, the upper four bits of the acknowledge response are undefined — they hold the same values as the upper four bits of the previously issued command. When the SIO0 is configured for I/O Interface mode, the boot program does not check for a receive error.

If the 3rd byte is equal to any of the command codes listed in Table 3.5 on page 37, the boot program echoes it back to the controller. When the Show Flash Memory Sum command was received, the boot program echoes back a value of 20H and then branches to the Show Flash Memory Sum routine.

If the 3rd byte is not a valid command, the boot program sends back x1H to the controller and returns

to the state in which it waits for a command again. In this case, the upper four bits of the acknowledge response are undefined — they hold the same values as the upper four bits of the previously issued command.

- (4) The Show Flash Memory Sum routine adds all the bytes of the flash memory together. The 5th and 6th bytes, transmitted from the target board to the controller, indicate the upper and lower bytes of this total sum, respectively. For details on sum calculation, see Section 3.5.13.
- (5) The 7th byte is a checksum value for the 5th and 6th bytes. To calculate the checksum value, add the 5th and 6th bytes together, drop the carry and take the two's complement of the sum. Transmit this checksum value from the controller to the target board.
- (6) The 8th byte is the next command code.

3.5.9 Show Product Information Command

See Table 3.8.

- (1) The processing of the 1st and 2nd bytes are the same as for the RAM Transfer command.
- (2) The 3rd byte, which the target board receives from the controller, is a command. The code for the Show Product Information command is 30H.
- (3) The 4th byte, transmitted from the target board to the controller, is an acknowledge response to the 3rd byte. Before sending back the acknowledge response, the boot program checks for a receive error. If there was a receive error, the boot program transmits x8H and returns to the state in which it waits for a command again. In this case, the upper four bits of the acknowledge response are undefined — they hold the same values as the upper four bits of the previously issued command. When the SIO0 is configured for I/O Interface mode, the boot program does not check for a receive error.

If the 3rd byte is equal to any of the command codes listed in Table 3.5 on page 37, the boot program echoes it back to the controller. When the Show Flash Memory Sum command was received, the boot program echoes back a value of 30H and then branches to the Show Flash Memory Sum routine.

If the 3rd byte is not a valid command, the boot program sends back x1H to the controller and returns to the state in which it waits for a command again. In this case, the upper four bits of the acknowledge response are undefined — they hold the same values as the upper four bits of the previously issued command.

- (4) The 5th to 8th bytes, transmitted from the target board to the controller, are the data read from addresses 0x0000_03F0–0x0000_03F3 in the flash memory. Software version management is possible by storing a software id in these locations.
- (5) The 9th to 20th bytes, transmitted from the target board to the controller, indicate the product name, which is “TX1962F10___” in ASCII code (where _ is a space).

- (6) The 21st to 24th bytes, transmitted from the target board to the controller, indicate the start address of the flash memory area containing the password, i.e., F4H, 03H, 00H, 00H.
- (7) The 25th to 28th bytes, transmitted from the target board to the controller, indicate the start address of the on-chip RAM, i.e., 00H, 60H, FDH, FFH.
- (8) The 29th to 32nd bytes, transmitted from the target board to the controller, are dummy data (FFH, 6FH, FDH, FFH).
- (9) The 33rd to 36th bytes, transmitted from the target board to the controller, indicate the end address of the on-chip RAM, i.e., FFH, FFH, FDH, FFH.
- (10) The 37th to 40th bytes, transmitted from the target board to the controller, are 00H, 70H, FDH and FFH.
The 41st to 44th bytes, transmitted from the target board to the controller, are FFH, EFH, FDH and FFH.
- (11) The 45th and 46th bytes, transmitted from the target board to the controller, indicate the presence or absence of the security and protect bits and whether the flash memory is divided into blocks. Bit 0 indicates the presence or absence of the security bit; it is 0 if the security bit is available. Bit 1 indicates the presence or absence of the protect bits; it is 0 if the protect bits are available. If bit 2 is 0, it indicates that the flash memory is divided into blocks. The remaining bits are undefined. The 45th and 46th bytes are 01H, 00H.
- (12) The 47th to 50th bytes, transmitted from the target board to the controller, indicate the start address of the on-chip flash memory, i.e., 00H, 00H, 00H, 00H.
- (13) The 51st to 54th bytes, transmitted from the target board to the controller, indicate the end address of the on-chip flash memory, i.e., FFH, FFH, 0FH, 00H.
- (14) The 55th to 56th bytes, transmitted from the target board to the controller, indicate the number of flash blocks available, i.e., 08H, 00H.
- (15) The 57th to 92nd bytes, transmitted from the target board to the controller, contain information about the flash blocks.
Flash blocks of the same size are treated as a group. Information about the flash blocks indicate the start address of a group, the size of the blocks in that group (in halfwords) and the number of the blocks in that group.
The 57th to 65th bytes are the information about the 128-kbyte blocks (Block 0 to Block 7). See Table 3.8 for the values of bytes transmitted.
- (16) The 66th byte, transmitted from the target board to the controller, is a checksum value for the 5th to 65th bytes. The checksum value is calculated by adding all these bytes together, dropping the carry and taking the two's complement of the total sum.
- (17) The 67th byte is the next command code.

3.5.10 Acknowledge Responses

The boot program represents processing states with specific codes. Table 3.9 to Table 3.11 show the values of possible acknowledge responses to the received data. The upper four bits of the acknowledge response are equal to those of the command being executed. Bit 3 of the code indicates a receive error. Bit 0 indicates an invalid command error, a checksum error or a password error. Bit 1 and bit 2 are always 0. Receive error checking is not done in I/O Interface mode.

Table 3.9 ACK Response to the Serial Operation Mode Byte

Return Value	Meaning
86H	The SIO can be configured to operate in UART mode. (See Note)
30H	The SIO can be configured to operate in I/O Interface mode.

Note: If the serial operation mode is determined as UART, the boot program checks if the SIO can be programmed to the baud rate at which the operation mode byte was transferred. If that baud rate is not possible, the boot program aborts, without sending back any response.

Table 3.10 ACK Response to the Command Byte

Return Value	Meaning
x8H (See Note)	A receive error occurred while getting a command code.
x1H (See Note)	An undefined command code was received. (Reception was completed normally.)
10H	The RAM Transfer command was received.
20H	The Show Flash Memory Sum command was received.
30H	The Show Product Information command was received.

Note: The upper four bits of the ACK response are the same as those of the previous command code.

Table 3.11 ACK Response to the Checksum Byte

Return Value	Meaning
18H	A receive error occurred.
11H	A checksum or password error occurred.
10H	The checksum was correct.

3.5.11 Determination of a Serial Operation Mode

The first byte from the controller determines the serial operation mode. To use UART mode for communications between the controller and the target board, the controller must first send a value of 86H at a desired baud rate to the target board. To use I/O Interface mode, the controller must send a value of 30H at 1/16 the desired baud rate. Figure 3.9 shows the waveforms for the first byte.

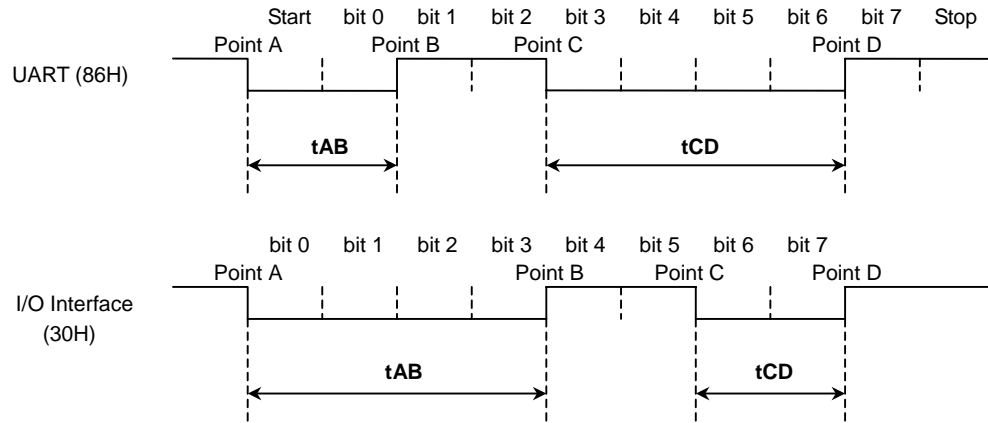

Figure 3.9 Serial Operation Mode Byte

After $\overline{\text{RESET}}$ is released, the boot program monitors the first serial byte from the controller, with the SIO reception disabled, and calculates the intervals of t_{AB} , t_{AC} and t_{AD} . Figure 3.10 shows a flowchart describing the steps to determine the intervals of t_{AB} , t_{AC} and t_{AD} . As shown in the flowchart, the boot program captures timer counts each time a logic transition occurs in the first serial byte. Consequently, the calculated t_{AB} , t_{AC} and t_{AD} intervals are bound to have slight errors. If the transfer goes at a high baud rate, the CPU might not be able to keep up with the speed of logic transitions at the serial receive pin. In particular, I/O Interface mode is more prone to this problem since its baud rate is generally much higher than that for UART mode. To avoid such a situation, the controller should send the first serial byte at 1/16 the desired baud rate.

The flowchart in Figure 3.11 shows how the boot program distinguishes between UART and I/O Interface modes. If the length of t_{AB} is equal to or less than the length of t_{CD} , the serial operation mode is determined as UART mode. If the length of t_{AB} is greater than the length of t_{CD} , the serial operation mode is determined as I/O Interface mode. Bear in mind that if the baud rate is too high or the timer operating frequency is too low, the timer resolution will be coarse, relative to the intervals between logic transitions. This becomes a problem due to inherent errors caused by the way in which timer counts are captured by software; consequently the boot program might not be able to determine the serial operation mode correctly.

For example, the serial operation mode may be determined to be I/O Interface mode when the intended mode is UART mode. To avoid such a situation, when UART mode is utilized, the controller should allow for a time-out period within which it expects to receive an echo-back (86H) from the target board. The controller should give up the communication if it fails to get that echo-back within the allotted time. When I/O Interface mode is utilized, once the first serial byte has been transmitted, the controller should send the SCLK clock after a certain idle time to get an acknowledge response. If the received acknowledge response is not 30H, the controller should give up further communications.

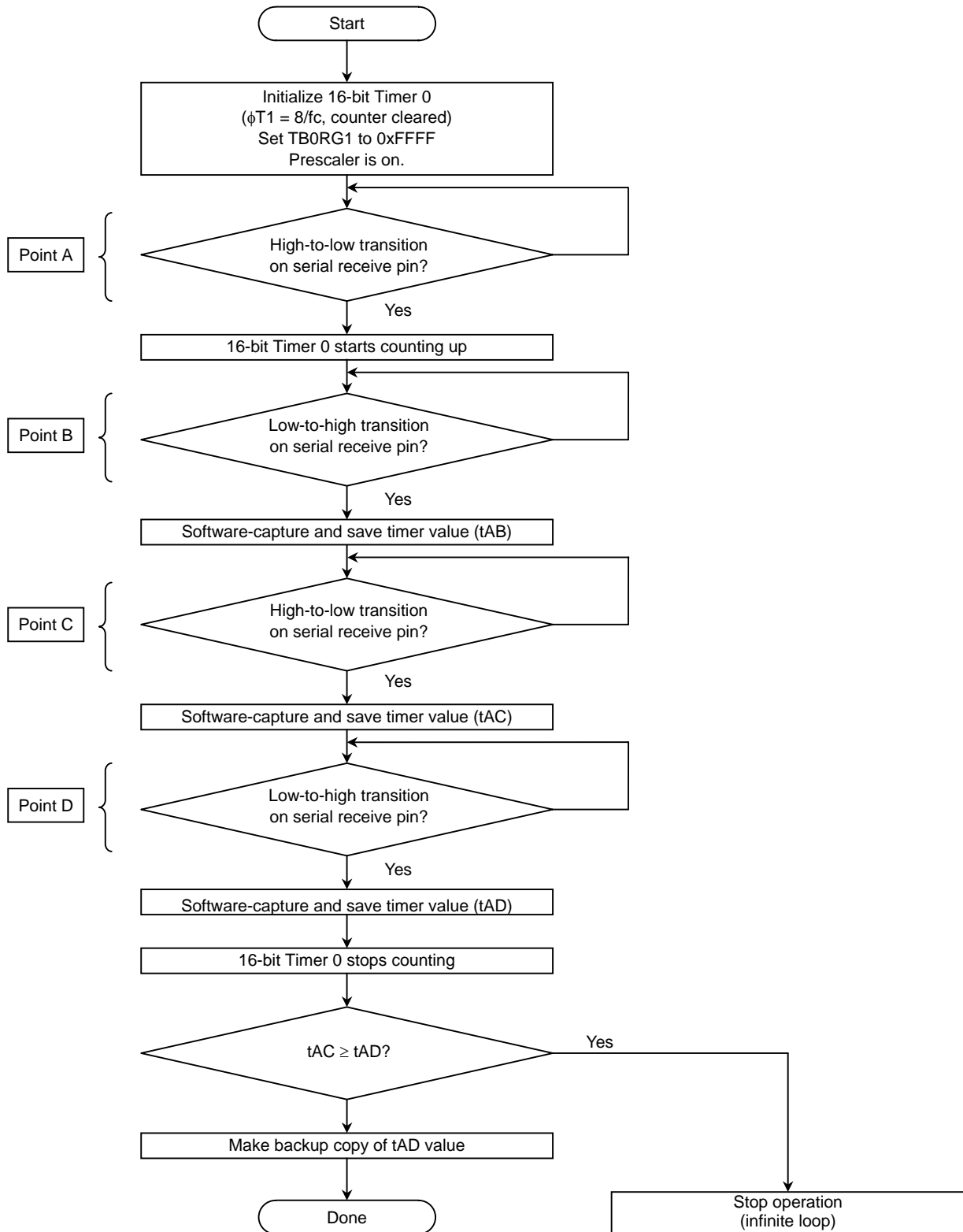

Figure 3.10 Serial Operation Mode Byte Reception Flow

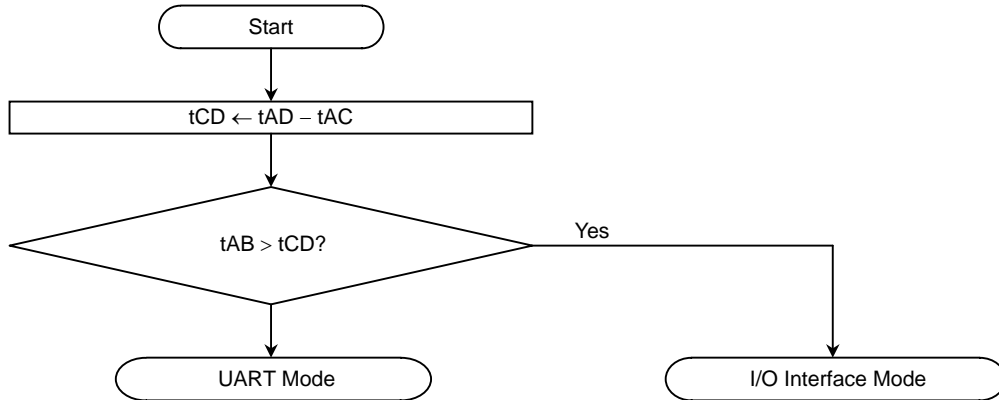

Figure 3.11 Serial Operation Mode Determination Flow

3.5.12 Password

The RAM Transfer command (10H) causes the boot program to perform a password check. Following an echo-back of the command code, the boot program checks the contents of the 12-byte password area (0x4000_03F4 to 0x4000_03FF) within the flash memory. If all these address locations contain the same bytes of data other than FFH, a password area error occurs. In this case, the boot program returns an error acknowledge (11H) in response to the checksum byte (the 17th byte), regardless of whether the password sequence sent from the controller is all FFHs.

The password sequence received from the controller (5th to 16th bytes) is compared to the password stored in the flash memory. Table 3.12 shows how they are compared byte-by-byte. All of the 12 bytes must match to pass the password check. Otherwise, a password error occurs, which causes the boot program to return an error acknowledge in response to the checksum byte (the 17th byte).

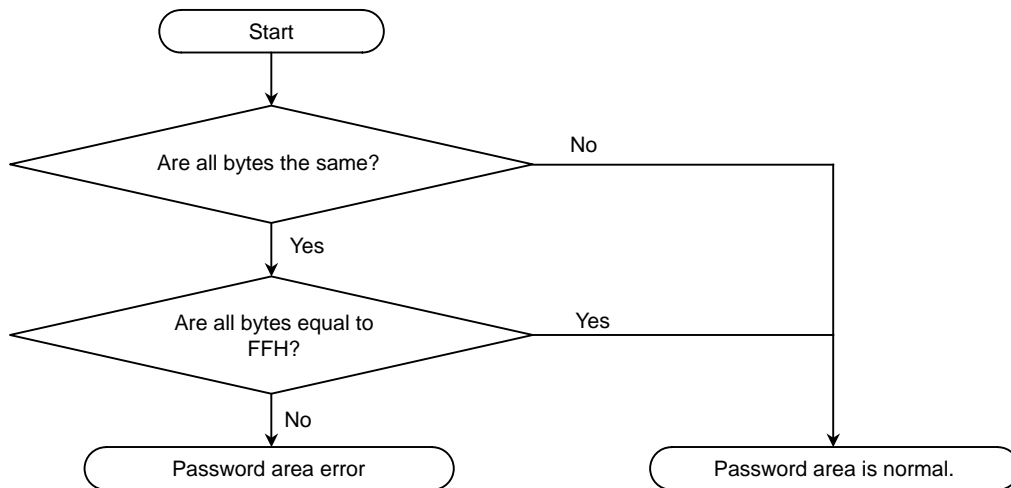

Figure 3.12 Password Area Check Flow

Table 3.12 Relationship between Received Bytes and Flash Memory Locations

Received Byte	Compared Flash Memory Data
5th byte	Address 0x0000_03F4
6th byte	Address 0x0000_03F5
7th byte	Address 0x0000_03F6
8th byte	Address 0x0000_03F7
9th byte	Address 0x0000_03F8
10th byte	Address 0x0000_03F9
11th byte	Address 0x0000_03FA
12th byte	Address 0x0000_03FB
13th byte	Address 0x0000_03FC
14th byte	Address 0x0000_03FD
15th byte	Address 0x0000_03FE
16th byte	Address 0x0000_03FF

3.5.13 Calculation of the Show Flash Memory Sum Command

The Show Flash Memory Sum command adds all 1024 kbytes of the flash memory together and provides the total sum as a halfword quantity. The sum is sent to the controller, with the upper eight bits first, followed by the lower eight bits.

Example:

A1H
B2H
C3H
D4H

For the interest of simplicity, assume the depth of the flash memory is four locations. Then the sum of the four bytes is calculated as:

$$A1H + B2H + C3H + D4H = 02EAH$$

Hence, 02H is first sent to the controller, followed by EAH.

3.5.14 Checksum Calculation

The checksum byte for a series of bytes of data is calculated by adding the bytes together, dropping the carries, and taking the two's complement of the total sum. The Show Flash Memory Sum command and the Show Product Information command perform the checksum calculation. The controller must perform the same checksum operation in transmitting checksum bytes.

Example:

Assume the Show Flash Memory Sum command provides the upper and lower bytes of the sum as E5H and F6H. To calculate the checksum for a series of E5H and F6H:

- (1) Add the bytes together.

$$E5H + F6H = 1DBH$$

- (2) Drop the carry.

- (3) Take the two's complement of the sum, and that is the checksum byte.

$$0 - DBH = 25H$$

3.5.15 General Boot Program Flowchart

Figure 3.13 shows an overall flowchart of the boot program.

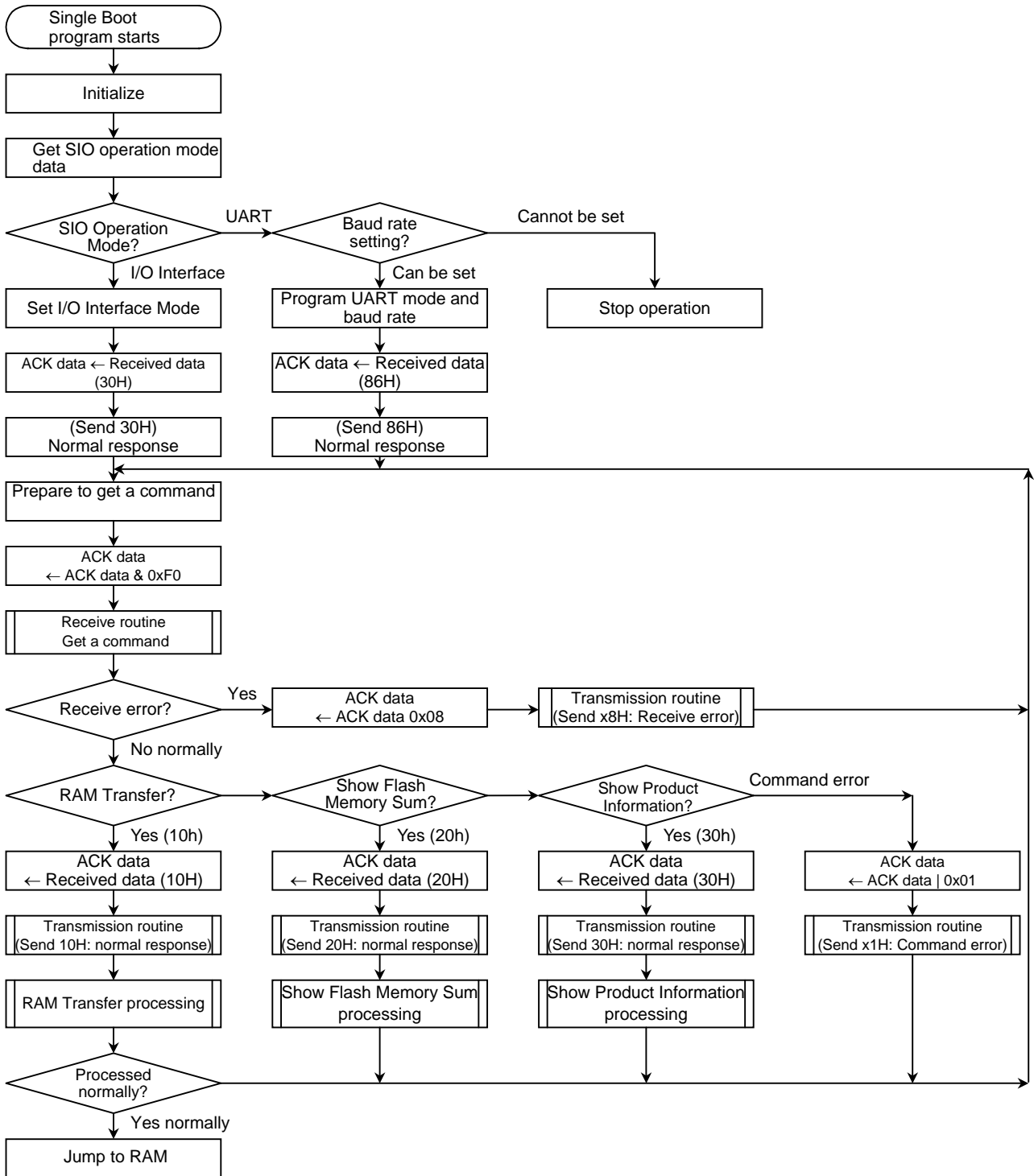

Figure 3.13 Overall Boot Program Flow

3.6 On-Board Programming and Erasure

The TMP1962F10AXBG flash memory is command set compatible with the JEDEC EEPROM standard, with a few exceptions. In User Boot mode and Single Boot mode (the RAM Transfer command), the flash memory can be programmed and erased by the CPU executing software commands. It is the user's responsibility to create a program/erase routine. Because the flash memory can not be read while it is being programmed or erased, the program/erase routine must be executed out of the on-chip RAM or an external memory device.

3.6.1 Key Features

The TMP1962F10AXBG flash memory commands are in principle compatible with the standard JEDEC commands. For program/erase operations, the system can issue a command sequence to the flash memory by using CPU instructions such as LD. After the command sequence is written, the flash memory does not require the system to provide further controls or timings. The flash memory initiates the embedded program or erase algorithm automatically. The entire flash memory or one or more flash blocks can be erased at a time.

Table 3.14 Flash Memory Features

Feature	Description
Auto Program	Programs and verifies the desired addresses word by word automatically.
Auto Chip Erase	Erases and verifies the entire memory array automatically.
Auto Block Erase	Erases and verifies all memory locations in the selected block automatically.
Auto Multi-Block Erase	Erases and verifies all memory locations in multiple selected blocks automatically.
Write operation status	Provides several status bits such as the Data Polling bit and Toggle bit, which can be used to determine whether a program or erase operation is complete or in progress.
Security feature	Prevents intrusive access to the flash memory while in Programmer mode. When the security feature is turned off, the entire memory array is erased and verified automatically, regardless of whether a given block is protected or not.
Block protection	Disables both program and erase operations in any block.

Bear in mind that, due to the on-chip CPU interface, the TMP1962F10AXBG uses addresses different from those of the standard flash command sequences. Unless otherwise noted, programming is done word by word; thus the word load instruction should be used to write to the flash array.

3.6.2 Block Architecture

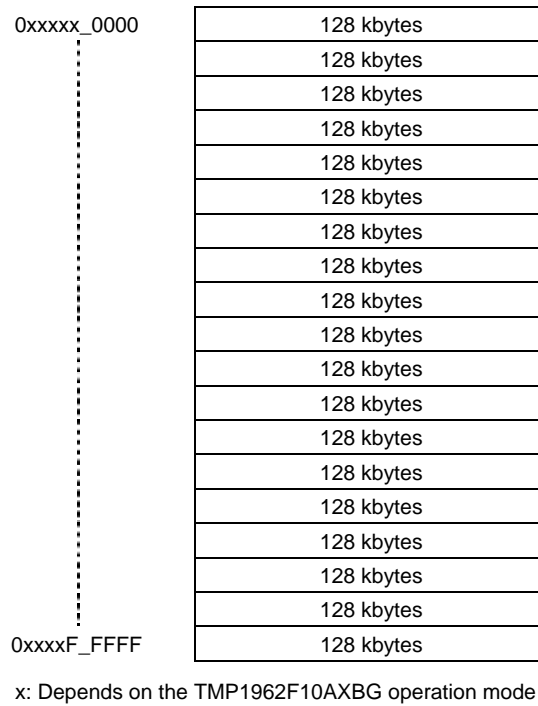

Figure 3.16 Flash Memory Block Architecture

3.6.3 CPU-to-Flash Interface

Figure 3.17 illustrates the internal interface between the CPU and the flash memory in on-board programming modes. The diagram does not show the actual logic network; instead it is only a conceptual depiction of the CPU-to-flash interface.

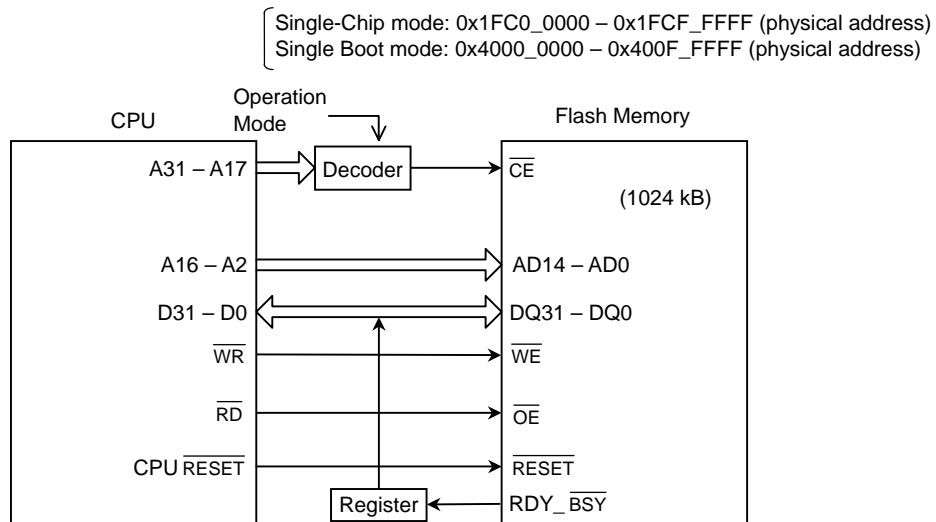

Figure 3.17 Internal CPU-to-Flash Interface

3.6.4 Read Mode and Embedded Operation Mode

The flash memory of the TMP1962F10AXBG has the following two modes of operation:

- Read mode in which array data is read
- Embedded Operation mode in which the flash array is programmed or erased

The flash memory enters Embedded Operation mode when a valid command sequence is executed in Read mode. In Embedded Operation mode, array data can not be read.

3.6.5 Reading Array Data

The flash memory is automatically set to reading array data upon CPU reset after device power-up and after an embedded operation is successfully completed. If an embedded operation terminated abnormally or the flash memory is required to return to the Read mode, the Read/Reset command (software reset) or hardware reset is used.

3.6.6 Writing Commands

The operations of the flash memory are selected by commands or command sequences written into the internal command register. This uses the same mechanism as for JEDEC-standard EEPROMs. Commands are made up of data sequences written at specific addresses via the command register. See Table 3.16 on page 63 for the list of command sequences.

The command sequence being written can be canceled by issuing the Read/Reset command between sequence cycles. The Read/Reset command clears the command register and resets the flash memory to Read mode. Invalid command sequences also cause the flash memory to clear the command register and return to Read mode.

3.6.7 Reset

- Read/Reset command (software reset)

The flash memory does not return to Read mode if an embedded operation terminated abnormally. In this case, the Read/Reset command must be issued to put the flash memory back in Read mode. The Read/Reset command may also be written between sequence cycles of the command being written to clear the command register.

- Hardware reset ($\overline{\text{RESET}}$ input)

As shown in Figure 3.17, the flash memory has a reset pin, which is connected to the reset signal of the CPU. When the system drives the $\overline{\text{RESET}}$ pin to V_{IL} or when certain events such as a watchdog timer time-out causes a CPU reset, the flash memory immediately terminates any operation in progress and is reset to Read mode.

The Read/Reset command is also tied to the $\overline{\text{RESET}}$ pin to reset the flash memory to Read mode. The embedded operation that was interrupted should be re-initiated once the flash memory is ready to accept another command sequence because data may be corrupted.

For a description of the hardware reset operation, see Section 3.3.2, *Reset Operation*. When a valid reset is achieved, the CPU reads the Reset exception vector from the flash memory and services the Reset exception.

3.6.8 Auto Program Command

A bit must be programmed to change its state from a 1 to a 0. A bit can not be programmed from a 0 back to a 1. Only an erase operation can change a 0 back to a 1.

In User Boot mode and the RAM Transfer command of Single Boot mode, the Auto Program command programs the desired addresses word by word. The Auto Program command requires four bus cycles; the program address and data are written in the fourth cycle, upon completion of which the program operation will commence. As programming is performed on a word-by-word basis, the program address must be a multiple of four.

Writing data shorter than a 32-bit word requires special considerations for the bits that are not to be altered. The word in the memory does not need to be in the erased state prior to programming. If the word is in the erased state, a 32-bit write must be performed, with all the bits not to be altered set to 1.

Examples:

- When a word location is in the erased state

To program the least-significant byte of that word to 55H, 0xFFFF_FF55 must be written to the word address.

Note : The superscription of data cannot be done in the flash memory.

The Auto Program command executes a sequence of internally timed events to program the desired bits of the addressed memory word and verify that the desired bits are sufficiently programmed. The system can determine the status of the programming operation by using write status flags (see Table 3.19 on page 65).

Any commands written during the programming operation are ignored. A hardware reset immediately terminates the programming operation. The programming operation that was interrupted should be re-initiated once the flash memory is ready to accept another command sequence because data may be corrupted.

The block protection feature disables programming operations in any block. If an attempt is made to program a protected block, the Auto Program command does nothing; the flash memory returns to Read mode in approximately 3 μ m after the completion of the fourth bus cycle of the command sequence.

When the embedded Auto Program algorithm is complete, the flash memory returns to Read mode.

If any failure occurs during the programming operation, the flash memory remains locked in Embedded Operation mode. The system can determine this status by using write status flags. To put the flash memory back in Read mode, use the Read/Reset command to reset the flash memory or a hardware reset to reset the whole chip. In case of a programming failure, it is recommended to replace the chip or discontinue the use of the failing flash block.

3.6.9 Auto Chip Erase Command

The Auto Chip Erase command requires six bus cycles. The flash area is partitioned into two areas, that are Block 0 to Block 3 (Flash 0) and Block 4 to Block 7 (Flash 1). The chip erase operation is performed for individual area. Set A[19] (address 19) = 0 for Flash 0, and A[19] = 1 for Flash 1 by each bus cycle. After completion of the sixth bus cycle, the Auto Chip Erase operation will commence immediately. The embedded Auto Chip Erase algorithm automatically preprograms the entire memory for an all-0 data pattern prior to the erase; then it automatically erases and verifies the entire memory for an all-1 data pattern. The system can determine the status of the chip erase operation by using write status flags (see

Table 3.19 on page 65).

Any commands written during the chip erase operation are ignored. A hardware reset immediately terminates the chip erase operation. The chip erase operation that was interrupted should be re-initiated once the flash memory is ready to accept another command sequence because data may be corrupted.

The block protection feature disables erase operations in any block. The Auto Chip Erase algorithm erases the unprotected blocks and ignores the protected blocks. If all the blocks are protected, the Auto Chip Erase command does nothing; the flash memory returns to Read mode in approximately 100 μm after the completion of the sixth bus cycle of the command sequence.

When the embedded Auto Chip Erase algorithm is complete, the flash memory returns to Read mode.

If any failure occurs during the erase operation, the flash memory remains locked in Embedded Operation mode. The system can determine this status by using write status flags. To put the flash memory back in Read mode, use the Read/Reset command to reset the flash memory or a hardware reset to reset the whole chip. In case of an erase failure, it is recommended to replace the chip or discontinue the use of the failing flash block. The failing block can be identified by means of the Block Erase command.

3.6.10 Auto Block Erase and Auto Multi-Block Erase Commands

The Auto Block Erase command requires six bus cycles. A time-out begins from the completion of the command sequence. After a time-out, the erase operation will commence. The embedded Auto Block Erase algorithm automatically preprograms the selected block for an all-0 data pattern, and then erases and verifies that block for an all-1 data pattern.

During the time-out period, additional block addresses and Auto Block Erase commands may be written. Multi-block is selectable in either Flash 0 area or Flash 1 area.

Any command other than Auto Block Erase during the time-out period resets the flash memory to Read mode. The block erase time-out period is 50 μm . The system may read DQ3 to determine whether the time-out period has expired. The block erase timer begins counting upon completion of the sixth bus cycle of the Auto Block Erase command sequence. The system can determine the status of the erase operation by using write status flags (see Table 3.19 on page 65).

Any commands written during the block erase operation are ignored. A hardware reset immediately terminates the block erase operation. The block erase operation that was interrupted should be re-initiated once the flash memory is ready to accept another command sequence because data may be corrupted.

The block protection feature disables erase operations in any block. The Auto Block Erase algorithm erases the unprotected blocks and ignores the protected blocks. If all the selected blocks are protected, the Auto Block Erase algorithm does nothing; the flash memory returns to Read mode in approximately 100 μm after the final bus cycle of the command sequence. When the embedded Auto Block Erase algorithm is complete, the flash memory returns to Read mode.

If any failure occurs during the erase operation, the flash memory remains locked in Embedded Operation mode. The system can determine this status by using write status flags. To put the flash memory back in Read mode, use the Read/Reset command to reset the flash memory or a hardware reset to reset the whole chip. In case of an erase failure, it is recommended to replace the chip or discontinue the use of the failing flash block. If any failure occurred during the multi-block erase operation, the failing block can be identified by running Auto Block Erase on each of the blocks selected for multi-block erasure.

3.6.11 Block Protect Command

The block protection feature disables both program and erase operations in any block. After completion of the seventh bus write cycle, FCLS<bit2> is 0 during Block Protect operation, and 1 after Block Protect operation.

Table 3.15 Effects of the Program and Erase Commands on the Protected Blocks

Command	Operation
Program command on a protected block	No programming operation is performed, and the flash memory automatically returns to Read mode.
Block Erase command on a protected block	No erase operation is performed, and the flash memory automatically returns to Read mode.
Chip Erase command when all the blocks are protected	No erase operation is performed, and the flash memory automatically returns to Read mode.
Chip Erase command when any blocks are protected	Only the unprotected blocks are erased. Upon completion, the flash memory automatically returns to Read mode.
Multi-Block Erase command when any blocks are protected	Only the unprotected blocks are erased. Upon completion, the flash memory automatically returns to Read mode.

Any commands written during the Block Protect algorithm are ignored. A hardware reset immediately terminates the block protect operation. The Block Protect command that was interrupted should be re-initiated once the flash memory is ready to accept another command sequence.

3.6.12 Block Unprotect Operation

Block unprotect operation is performed for individual area (Flash 0 and Flash 1). Set A[19] in accordance to the area required for block unprotect by the bus cycle. After completion of the seventh bus write cycle, FCLS<bit2> is 0 during block unprotect operation, and 1 after block unprotect operation.

Any commands written during the Block Unprotect algorithm are ignored. The hardware reset immediately terminates the block unprotect operation. The Block Protect command should be reinitiated once the flash memory is ready to accept another command sequence. Use the Verify Block Protect command to verify the protect status of a block.

3.6.13 Verify Block Protect Command

The Verify Block Protect command is used to verify the protect status of a block. Verify Block Protect is a four-bus-cycle operation. The address of the block to be verified is given in the fourth cycle. Any address within the block range will suffice, provided A0 = A1 = A2 = A3 = 0, A4 = 1 and A6 = 0. To get correct data, a 32-bit read must be performed. Use the last read as valid data. If the selected block is protected, a value of 0x0000_0001 is returned. If the selected block is not protected, a value of 0x0000_0000 is returned. Following the fourth bus cycle, an additional block address may be read.

The Verify Block Protect command does not return the flash memory to Read mode. Either the Read/Reset command or a hardware reset is required to reset the flash memory to Read mode or to write the next command.

3.6.14 Write Operation Status

As shown in Table 3.19, the flash memory provides several flag bits to determine the status of an embedded operation: DQ7, DQ5 and DQ3. These status bits can be read during an embedded operation using the same timing as for Read mode. The flash memory automatically returns to Read mode when an embedded operation completes. The status of an embedded program operation can be monitored to determine whether the hardware sequence flag during an embedded operation, or the data read after completion of an embedded operation match the cell data. Read of the hardware sequence flag is performed by checking start of embedded operation (FLCS<bit2>=0).

During the embedded program operation, the system must provide the program address (with A0 = 0 and A1 = 0) to read valid status information. During the embedded erase operation, the system must provide an address (with A0 = 0 and A1 = 0) within any of the blocks selected for erasure to read valid status information.

- DQ7 (Data Polling)

The Data Polling bit, DQ7, indicates to the host system the status of the embedded operation. Data Polling is valid after the final bus write cycle of an embedded command sequence.

When the embedded Program algorithm is in progress, an attempt to read the flash memory will produce the complement of the data last written to DQ7. Upon completion of the embedded Program algorithm, an attempt to read the flash memory will produce the true data last written to DQ7. Therefore, the system can use DQ7 to determine whether the embedded Program algorithm is in progress or complete.

When the embedded Erase algorithm is in progress, an attempt to read the flash memory will produce a 0 at the DQ7 output. Upon completion of the embedded Erase algorithm, the flash memory will produce a 1 at the DQ7 output.

If there is a failure during an embedded operation, DQ7 continues to output the same value. Thus, DQ7 must always be polled in conjunction with the Exceeded Timing Limits (DQ5) flag. Figure 3.21 shows the DQ7 polling algorithm.

The flash memory disables address latching when an embedded operation is complete. Data polling must be performed with a valid programmed address or an address within any of the non-protected blocks selected for erasure.

- DQ5 (Exceeded Timing Limits)

DQ5 produces a 0 while the program or erase operation is in progress normally. DQ5 produces a 1 to indicate that the program or erase time has exceeded the specified internal limit. This is a failure condition that indicates the program or erase cycle was not successfully completed.

The DQ5 failure condition also appears if the system tries to program a 1 to a location that was previously programmed to a 0. Only an erase operation can change a 1 back to a 0. In this case, the embedded Program algorithm halts the operation. Once the operation has exceeded the timing limits, DQ5 will indicate a 1. Note that this is not a device failure condition since the flash memory was used incorrectly.

Under both these conditions, the flash memory remains locked in Embedded Operation mode. The system must issue the Read/Reset command to return the flash memory to Read mode.

- DQ3 (Block Erase Timer)

After the completion of the sixth bus cycle of the Auto Block Erase command sequence, the block erase time-out window of 50 μ m begins. The erase operation will begin after the time-out has expired. When the time-out is complete and the erase operation has begun, DQ3 switches from 0 to 1. If DQ3 is 0, the flash memory will accept additional Auto Block Erase commands. Each time an Auto Block Erase command is written, the time-out window is reset. To ensure that the command has been accepted, the system should check DQ3 prior to and following each Auto Block Erase command. If DQ3 is 1 on the second status check, the command might not have been accepted.

3.6.15 Flash Control/Status Register

This is an 8-bit register that indicates the Ready/Busy status of an embedded algorithm and controls the security feature.

		7	6	5	4	3	2	1	0
FLCS (0xFFFF_E520)	Bit Symbol	FLRMSK					RDY/BSY		
	Read/Write	W					R		
	Reset Value	0					1	0	
	Function	Flash reset mask enable 1: Reset a flash control circuitry 0: Unreset a flash control circuitry					Ready/ Busy 0: Embedded algorithm is in progress. 1: Embedded algorithm is complete.	Must be written as "0".	

Figure 3.18 Flash Control/Status Register

- Bit 2: Ready/Busy Flag Bit(

In Programmer mode, the ALE pin functions as the RDY/ $\overline{\text{BSY}}$ pin. The host system can monitor the state of this pin to determine whether an embedded algorithm is in progress or complete. The CPU can poll the RDY/BSY bit in the FLCS register for the same purpose. The RDY/BSY bit is cleared to 0 when the flash memory is actively erasing or programming. The RDY/BSY bit is set to 1 when an embedded operation has completed and the flash memory is ready to accept the next command. If any failure occurs during the program or erase operation, this bit remains cleared. A hardware reset sets this bit.

The RDY/BSY bit is cleared upon completion of the final bus write cycle of an embedded operation command, with one exception. In the case of the Auto Block Erase command, this bit is cleared after the time-out has expired. Any command is ignored while the RDY/BSY bit is cleared.

- Bit 7: Flash Reset Mask Bit

An interval of 30 μ s (T.B.D.) is allowed to elapse before starting the processor core operation after a reset upon power on, which is required to initialize an on-chip flash control circuitry. SYSRDY is signaled to indicate the start of the processor core operation from outside of TMP1962. After the processor core is reset, SYSRDY switches from Low to High. The reset operation after power on (do not power off) is controlled by bit 7 (FLRMSK) of the flash control/status register (FLCS) in the flash control part. When the FLRMSK bit is 0 (initial value), the flash control circuitry is always initialized. When the FLRMSK bit is set to 1, the flash control circuitry is not initialized. (Read of the on-chip flash memory is performed correctly.) In this case, the interval of 30 μ s (T.B.D.) is not required for the flash control circuitry to be stable after a reset. Immediately the processor core starts operation, and the SYSRDY signal switches to High. The value set to the FLRMSK bit is retained until power off. Set FLRMSK=1 commonly by initial setting after reset.

Note: The Flash Control/Status register must be accessed as a 32-bit quantity.

3.6.16 Flash Security

The TMP1962F10AXBG flash memory supports not only on-board programming but also programming using a general-purpose programmer. Therefore, the TMP1962F10AXBG flash memory provides a security feature to prevent intrusive access to the flash memory while in Programmer mode.

The TMP1962F10AXBG is secured by all eight blocks being protected, and the contents of a flash memory can not be read by a programmer.

- Securing the flash (Disabling read accesses)

Securing the flash memory disables a general-purpose programmer to read its contents. To turn on the security feature, once programming is complete, protect all eight blocks. That secures the flash memory. If one of eight blocks is unprotected, the flash memory is unsecured.

In on-board operating modes, the CPU can read the flash memory even if the security is on. When the security is ON, any reads by programming equipment will always return a word-length value of 0x0098.

- Unsecuring the flash (Enabling read accesses)

The security feature is designed to disable reads of the flash memory by programming equipment. While the TMP1962F10AXBG is soldered on a board, the CPU can always read the flash memory, regardless of whether or not the security is on. Since the flash memory is placed under control of a user's application program in on-board operating modes, it is not easy for third parties to perform intrusive access to the flash memory. Therefore, within the confines of a board, the flash memory does not need to be secured. To turn off the security feature, unprotect eight blocks. Unsecuring the flash memory enables the flash memory erase operation to occur before turning off the security feature. After a flash memory has been erased, the flash memory unsecure operation is completed by erasing the Block Protect bit.

3.6.17 Command Definition

Table 3.16 On-Board Programming Mode Command Definition

Command Sequence	Cycles Required	Bus Cycles									
		1st Cycle (Write)		2nd Cycle (Write)		3rd Cycle (Write)		4th Cycle (Read/Write)		5th Cycle (Read/Write)	
		Addr	Data	Addr	Data	Addr	Data	Addr	Data	Addr	Data
Read/Reset	1	0xFFFF	F0H								
Read/Reset	3	0x5554	AAH	0xAAA8	55H	0x5554	F0H	RA	RD		
Auto Program	4	0x5554	AAH	0xAAA8	55H	0x5554	A0H	PA	PD		
Auto Chip Erase	6	0x5554	AAH	0xAAA8	55H	0x5554	80H	0x5554	AAH	0xAAA8	55H
Auto Block Erase	6	0x5554	AAH	0xAAA8	55H	0x5554	80H	0x5554	AAH	0xAAA8	55H
Block Protect	7	0x5554	AAH	0xAAA8	55H	0x5554	9AH	0x5554	AAH	0xAAA8	55H
Block Unprotect	7	0x5554	AAH	0xAAA8	55H	0x5554	6AH	0x5554	AAH	0xAAA8	55H
ID Read/Block Protect Verify	4	0x5554	AAH	0xAAA8	55H	0x5554	90H	IA/BPA	ID/BD		

(Continued from above)

Command Sequence	Cycles Required	Bus Cycles			
		6th Cycle (Write)		7th Cycle (Write)	
		Addr	Data	Addr	Data
Read/Reset	1				
Read/Reset	3				
Auto Program	4				
Auto Chip Erase	6	0x5554	10H		
Auto Block Erase	6	BA	30H		
Block Protect	7	0x5554	9AH	BPA	9AH
Block Unprotect	7	0x5554	6AH	0x5554	6AH
Auto Security On (Note 1)	4				

Note 1: After every bus write cycle, execute SYNC and NOP in sequence.**Note 2:** Set the value corresponding the flash memory address to 16-bit through 19-bit in every bus write cycle.

The addresses to be provided by the CPU are shown below.

Table 3.17 Addresses Provided by the CPU

Command Address	CPU Addresses: A23–A0																
	A23–A16	A15	A14	A13	A12	A11	A10	A9	A8	A7	A6	A5	A4	A3	A2	A1	A0
0xFFFF0	Flash memory block	X	X	X	X	X	X	X	X	X	X	X	X	0	0	0	0
0x0000		0	0	0	0	0	0	0	0	0	0	0	0	0	0	0	0
0xAAA8		1	0	1	0	1	0	1	0	1	0	1	0	1	0	0	0
0x5554		0	1	0	1	0	1	0	1	0	1	0	1	0	1	0	0

- F0H, AAH, 55H, A0H, 80H, 10H, 30H:
Command data. Write command data as a byte quantity.
- RA: Read Address
RD: Read Data
- PA: Program Address
PD: Program Data
The address must be a multiple of four. Write data on a word-by-word basis.
- BA: Block Address (BA0–BA6)
Refer to Table 3.18.
- BPA: Verify Block Protect Address
BD: Block Protect Data
Refer to Table 3.18. The address of the block to be verified can be any of the addresses within the block, with A6 = 0, A4 = 1, A3 = 0, A1 = 0 and A0 = 0. If a block is protected, a value of 0x0000_0001 will be returned. If a block is not protected, a value of 0x0000_0000 will be returned.
- IA: ID Read Address
- ID: ID Data

Table 3.18 Block Erase Addresses

		User Boot Mode	Boot Mode		A19	A18	A17
Flash0	Block-0	0x1FC0_0000 - 0x1FC1_FFFF (or 0x4000_0000 - 0x4001_FFFF)	0x1FC0_0000 - 0x1FC1_FFFF	128 kbyte	0	0	0
	Block-1	0x1FC2_0000 - 0x1FC3_FFFF (or 0x4002_0000 - 0x4003_FFFF)	0x1FC2_0000 - 0x1FC3_FFFF	128 kbyte	0	0	1
	Block-2	0x1FC4_0000 - 0x1FC5_FFFF (or 0x4004_0000 - 0x4005_FFFF)	0x1FC4_0000 - 0x1FC5_FFFF	128 kbyte	0	1	0
	Block-3	0x1FC6_0000 - 0x1FC7_FFFF (or 0x4006_0000 - 0x4007_FFFF)	0x1FC6_0000 - 0x1FC7_FFFF	128 kbyte	0	1	1
Flash1	Block-4	0x1FC8_0000 - 0x1FC9_FFFF (or 0x4008_0000 - 0x4009_FFFF)	0x1FC8_0000 - 0x1FC9_FFFF	128 kbyte	1	0	0
	Block-5	0x1FCA_0000 - 0x1FCB_FFFF (or 0x400A_0000 - 0x400B_FFFF)	0x1FCA_0000 - 0x1FCB_FFFF	128 kbyte	1	0	1
	Block-6	0x1FCC_0000 - 0x1FCD_FFFF (or 0x400C_0000 - 0x400D_FFFF)	0x1FCC_0000 - 0x1FCD_FFFF	128 kbyte	1	1	0
	Block-7	0x1FCE_0000 - 0x1FCF_FFFF (or 0x400E_0000 - 0x400E_FFFF)	0x1FCE_0000 - 0x1FCF_FFFF	128 kbyte	1	1	1

The address of the block to be erased can be any of the addresses within that block with A0=0 and A1=0.

Example: To select BA0 in User Boot mode, provide any address in the range between 0x1FC0_0000 and 0x1FC1_FFFF.

Table 3.19 Write Status Flags

Status		D7 (DQ7)	D5 (DQ5)	D3 (DQ3)
Embedded operation in progress	Auto Program	$\overline{DQ7}$	0	0
	Auto Erase (during the time-out window)	0	0	0
	Auto Erase	0	0	1
Time-out in embedded operation	Auto Program	$\overline{DQ7}$	1	1
	Auto Erase	0	1	1

Note: D31–D8, D6, D4 and D2–D0 are don't-cares.

3.6.18 Embedded Algorithms

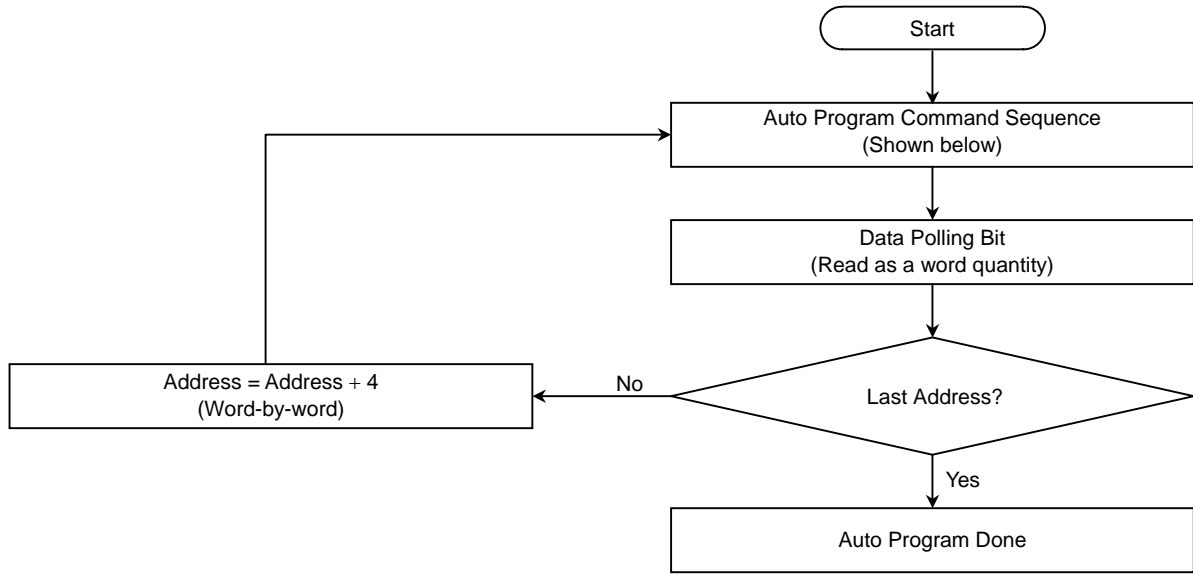

Auto Program Command Sequence (Address/Data)

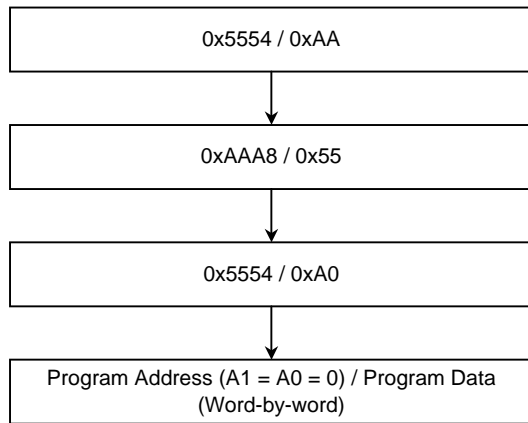

Figure 3.19 Auto Program Operation

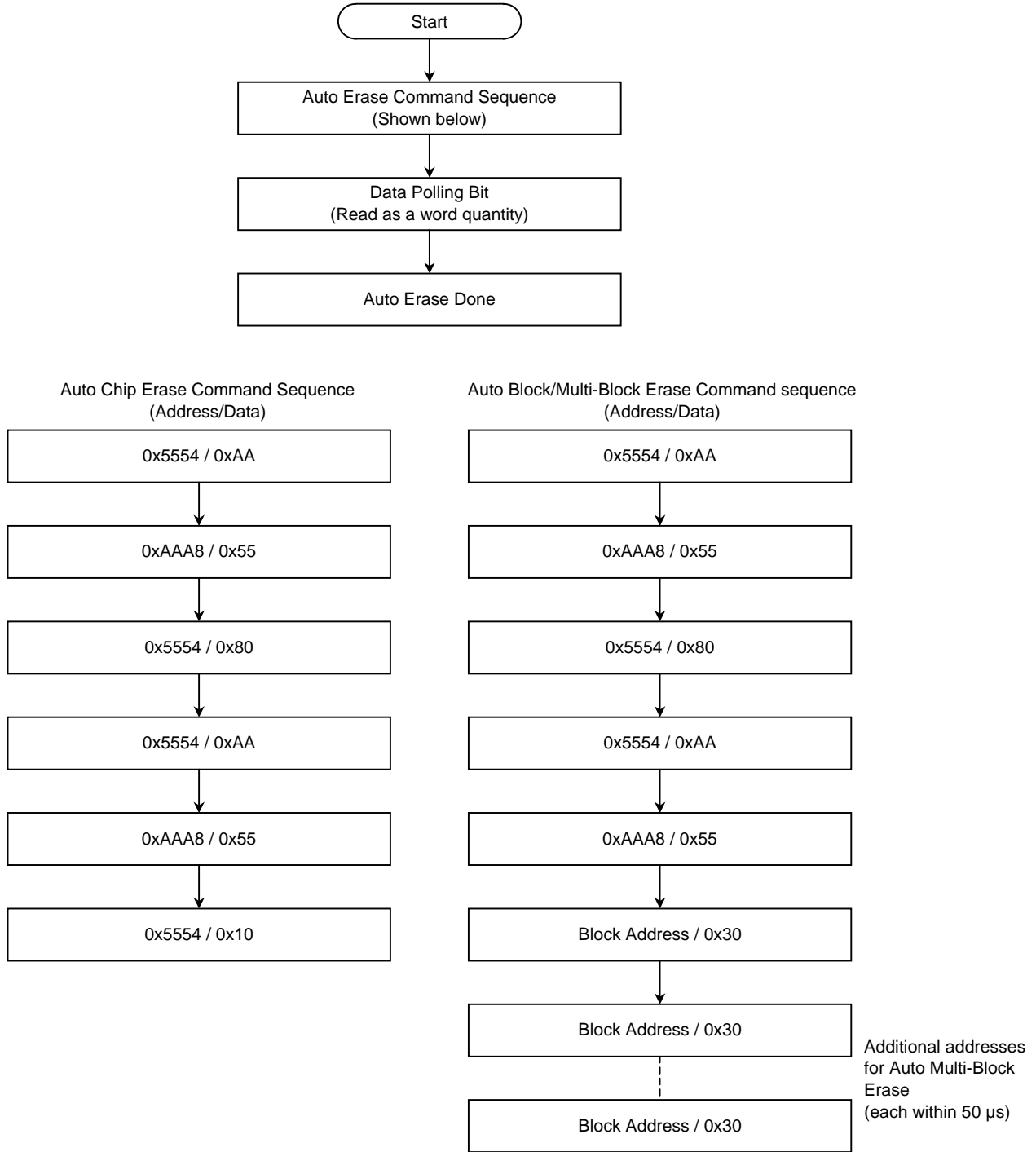

Figure 3.20 Auto Erase Operations

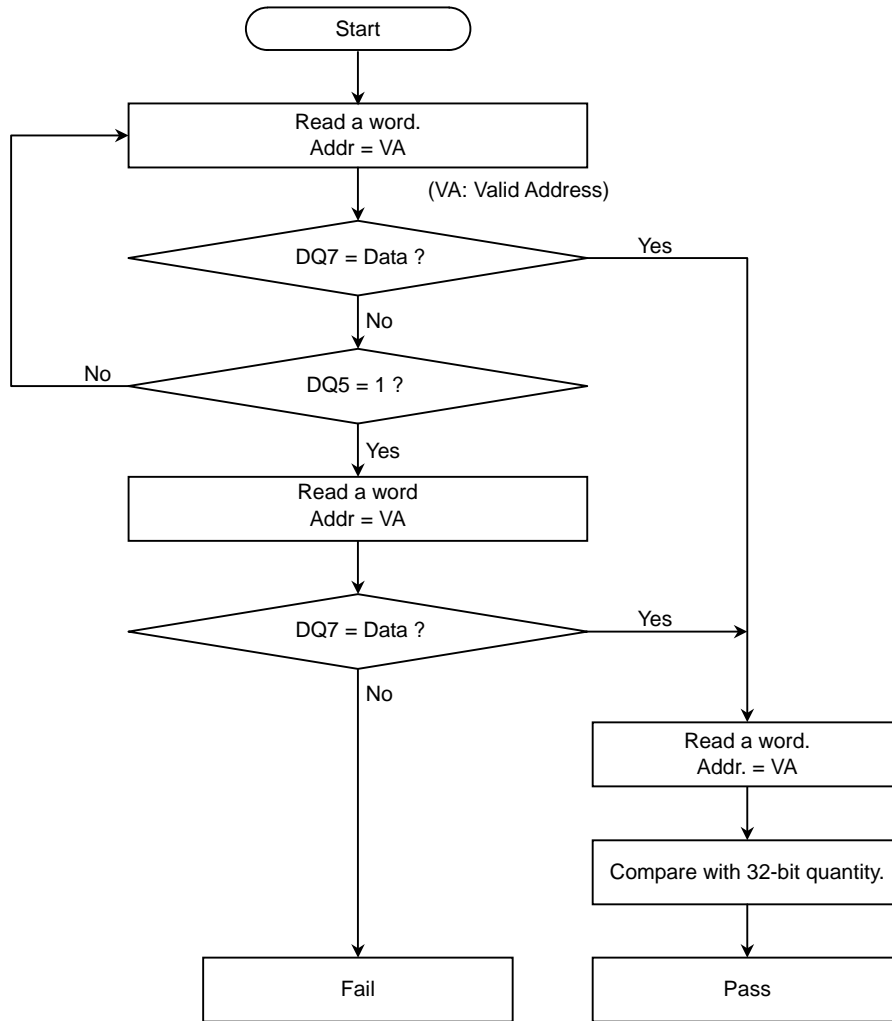

Figure 3.21 Data Polling (DQ7) Algorithm

4. Electrical Characteristics

The letter x in equations presented in this chapter represents the cycle period of the fsys clock selected through the programming of the SYSCR1.SYSCK bit. The fsys clock may be derived from either the high-speed or low-speed crystal oscillator. The programming of the clock gear function also affects the fsys frequency. All relevant values in this chapter are calculated with the high-speed (fc) system clock (SYSCR1.SYSCK = 0) and a clock gear factor of 1/fc (SYSCR1.GEAR[1:0] = 00).

4.1 Absolute Maximum Ratings

Parameter		Symbol	Rating	Unit
Supply voltage		V _{CC2} (Core)	-0.3 to 3.6	V
		V _{CC3} (I/O)	-0.3 to 4.0	
		AVCC (A/D)	-0.3 to 3.6	
		FVCC3 (L1 Pin)	-0.3 to 4.0	
Input voltage		V _{IN}	-0.3 to V _{CC} + 0.3	V
Low-level output current	Per pin	I _{OL}	5	mA
	Total	ΣI _{OL}	50	
High-level output current	Per pin	I _{OH}	-5	
	Total	ΣI _{OH}	50	
Power dissipation (Ta = 85°C)		PD	600	mW
Soldering temperature (10 s)		T _{SOLDER}	260	°C
Storage temperature		T _{STG}	-65 to 150	°C
Operating temperature	Except during flash W/E	T _{OPR}	-20 to 85	°C
	During flash W/E		10 to 60	
Write/erase cycles		NEW	100	cycle

V_{CC2} = DVCC21 = DVCC22 = FVCC2 = CVCC2, V_{CC3} = DVCC3n (n = 1 to 4),
 AVCC = AVCC31 = AVCC32, V_{SS} = DVSS = FVSS = AVSS = CVSS

Note: Absolute Maximum Ratings are limiting values of operating and environmental conditions which should not be exceeded under the worst possible conditions. The equipment manufacturer should design so that no Absolute Maximum Ratings value is exceeded with respect to current, voltage, power dissipation, temperature, etc. Exposure to conditions beyond those listed above may cause permanent damage to the device or affect device reliability, which could increase potential risks of personal injury due to IC blowup and/or burning.

4.2 DC Electrical Characteristics (1/4)

Ta = -20 to 85°C

Parameter	Symbol	Conditions	Min	Typ (Note 1)	Max	Unit
Supply voltage FVCC2 = CVCC2 = DVCC21 = DVCC22 FVSS = CVSS = DVSS = 0 V	DVCC2m (m = 1 to 2)	fosc = 10 to 13.5 MHz fsys = 3.75 to 40.5 MHz PLLON, INTLV = "H"	2.2		2.7	V
	DVCC3n (n = 1 to 4)	fsys = 3.75 to 40.5 MHz	1.65		3.3	
	FVCC3	fsys = 3.75 to 40.5 MHz	2.9		3.6	
Low-level input voltage	P7-P9 (Used as a port)	V_{IL1}	-0.3		$2.7\text{ V} \leq AVCC32 \leq AVCC31 \leq 3.5\text{ V}$	0.3 AVCC31 0.3 AVCC32
		$1.65 \leq AVCC32 \leq < 2.7\text{ V}$				
	P0-P6, PA-PC, PD0-PD6, PE0-PE2, PF2-PF7, PG-PH, PI7, PJ1-PJ4, PL-PP	V_{IL2}			$1.65\text{ V} \leq DVCC3n \leq 3.3\text{ V}$ (n = 1 to 4)	0.3 DVCC3n 0.2 DVCC2m
		V_{IL3}			$2.7\text{ V} \leq DVCC3n \leq 3.3\text{ V}$ (n = 1 to 4)	0.15 DVCC3n
		$1.65\text{ V} \leq DVCC3n < 2.7\text{ V}$ (n = 1 to 4) $2.2\text{ V} \leq DVCC2m \leq 2.7\text{ V}$ (m = 1 to 2)	0.1 DVCC3n 0.1 DVCC2m			
X1	V_{IL4}	$2.2\text{ V} \leq CVCC2 \leq 2.7\text{ V}$			0.1 CVCC2	V

Note 1: Ta = 25°C, DVCC3n = 3.0 V, DVCC2m = 2.5 V, AVCC3 = 3.3 V, unless otherwise noted.

4.3 DC Electrical Characteristics (2/4)

Ta = -20 to 85°C

Parameter	Symbol	Conditions		Min	Typ. (Note 1)	Max	Unit
High-level input voltage	P7-P9 (Used as a port)	V_{IH1}	$2.7\text{ V} \leq AVCC32 \leq AVCC31 \leq 3.5\text{ V}$	0.7 AVCC31			V
			$1.65 \leq AVCC32 < 2.7\text{ V}$	0.7 AVCC32			
	P0-P6, PA-PC, PD0-PD6, PE0-PE2, PF2-PF7, PG-PH, PI7, PJ1-PJ4, PL-PP	V_{IH2}	$1.65\text{ V} \leq DVCC3n \leq 3.3\text{ V}$ (n = 1 to 4)	0.7 DVCC3n			
			$2.2\text{ V} \leq DVCC2m \leq 2.7\text{ V}$ (m = 1 to 2)	0.8 DVCC2m			
PD7, PE3-PE7, PF0-PF1, PI0-PI6, PJ0, PK, \overline{PLLOFF} , \overline{RSTPUP} , \overline{RESET} \overline{DRESET} , \overline{DBG} $\overline{SDI}/\overline{DINT}$, TCK, TMS, TDI, \overline{TRST} \overline{NMI} , BW0, BW1	V_{IH3}	$2.7\text{ V} \leq DVCC3n \leq 3.3\text{ V}$ (n = 1 to 4)	0.85 DVCC3n				
		$1.65\text{ V} \leq DVCC3n < 2.7\text{ V}$ (n = 1 to 4) $2.2\text{ V} \leq DVCC2m \leq 2.7\text{ V}$ (m = 1 to 2)	0.9 DVCC3n 0.9 DVCC2m				
X1	V_{IH4}	$2.2\text{ V} \leq CVCC2 \leq 2.7\text{ V}$		0.9 CVCC2			
Low-level output voltage	V_{OL}	$I_{OL} = 2\text{ mA}$	$DVCC3n \geq 2.7\text{ V}$			0.4	V
		$I_{OL} = 500\text{ }\mu\text{A}$	$DVCC3n < 2.7\text{ V}$ $DVCC2m \leq 2.7\text{ V}$			0.2 DVCC3n ≤ 0.4 0.2 DVCC2 ≤ 0.4	
High-level output voltage	V_{OH}	$I_{OH} = -2\text{ mA}$	$DVCC3n \geq 2.7\text{ V}$	2.4			
		$I_{OH} = -500\text{ }\mu\text{A}$	$DVCC3n < 2.7\text{ V}$ $DVCC2m \leq 2.7\text{ V}$	0.8 DVCC3n 0.8 DVCC2			

Note 1: Ta = 25°C, DVCC3n = 3.0 V, DVCC2m = 2.5 V, AVCC3 = 3.3 V, unless otherwise noted.

4.4 DC Electrical Characteristics (3/4)

Ta = -20 to 85°C

Parameter	Symbol	Conditions	Min	Typ. (Note 1)	Max	Unit
Input leakage current	I_{LI}	$0.0 \leq V_{IN} \leq DVCC2m$ (m = 1 to 2) $0.0 \leq V_{IN} \leq DVCC3n$ (n = 1 to 4) $0.0 \leq V_{IN} \leq AVCC31$ $0.0 \leq V_{IN} \leq AVCC32$		0.02	±5	μA
Output leakage current	I_{LO}	$0.2 \leq V_{IN} \leq DVCC2m - 0.2$ (m = 1 to 2) $0.2 \leq V_{IN} \leq DVCC3n - 0.2$ (n = 1 to 4) $0.2 \leq V_{IN} \leq AVCC31 - 0.2$ $0.2 \leq V_{IN} \leq AVCC32 - 0.2$		0.05	±10	
Power-down voltage (STOP mode RAM backup)	V_{STOP} (DVCC2)	$V_{IL2} = 0.2DVCC2m$, $V_{IL3} = 0.1DVCC2m$ $V_{IH2} = 0.8DVCC2m$, $V_{IH3} = 0.9DVCC2m$	2.2		2.7	V
Pull-up resistor at Reset	RRST	$2.2 V \leq DVCC21 \leq 2.7 V$	20	50	240	kΩ
Schmitt W Idth PD7, PE3-PE7, PF0-PF1, PI0-PI6, PJ0, PK, $\overline{P}LLOFF$, $\overline{R}STPUP$, $\overline{R}ESE\overline{T}$, $\overline{D}RESET$, $\overline{D}BG\overline{E}$, $\overline{S}DI/\overline{D}INT$, TCK, TMS, TDI, $\overline{T}RST$, $\overline{N}MI$, BW0, BW1	V_{TH}	$2.7 V \leq DVCC3n \leq 3.3 V$ (n = 2, 4) $1.65 V \leq DVCC3n < 2.7 V$ (n = 2, 4) $2.2 V \leq DVCC2m \leq 2.7 V$ (m = 1 to 2)	0.4	0.9		V
			0.3	0.6		
Programmable pull-up/ pull-down resistor P32-P37, P40-P43 KEY0-KEYD, $\overline{D}RESET$, $\overline{D}BG\overline{E}$, $\overline{S}DI/\overline{D}INT$, TCK, TMS, TDI, $\overline{T}RST$	PKH	$DVCC3n = 3.0 V \pm 0.3 V$ (n = 2 to 4) $DVCC3n = 2.5 V \pm 0.2 V$ (n = 2 to 4) $DVCC3n = 2.0 V \pm 0.2 V$ (n = 2 to 4)	15	50	100	kΩ
			20	50	240	
			25	160	600	
Pin capacitance (Except power supply pins)	C_{IO}	fc = 1 MHz			10	pF

Note 1: Ta = 25°C, DVCC3n = 3.0 V, DVCC2m = 2.5 V, AVCC3 = 3.3 V, unless otherwise noted.

4.5 DC Electrical Characteristics (4/4)

$$DVCC2m = FVCC2 = CVCC2 = 2.5 \text{ V} \pm 0.2 \text{ V}, FVCC3 = 3.3 \text{ V} \pm 0.3 \text{ V},$$

$$DVCC3n = 3.0 \text{ V} \pm 0.3 \text{ V}, AVCC3m = 3.3 \text{ V} \pm 0.2 \text{ V}$$

$$T_a = -20 \text{ to } 85^\circ\text{C} \text{ (n = 1 to 4, m = 1, 2)}$$

Parameter	Symbol	Conditions	Min	Typ. (Note 1)	Max	Unit
NORMAL (Note 2): Gear = 1/1	I_{CC}	$f_{\text{sys}} = 40.5 \text{ MHz}$ (f _{OSC} = 13.5 MHz, PLLON) INTLV = "H"		90	110	mA
IDLE (Doze)				40	60	
IDLE (Halt)				33	50	
STOP		$DVCC2m = FVCC2 = CVCC2 = 2.2 \text{ to } 2.7 \text{ V}$ $DVCC3n = 1.65 \text{ to } 3.3 \text{ V}$ $AVCC3m = 2.7 \text{ to } 3.5 \text{ V}$ $FVCC3 = 3.0 \text{ to } 3.6 \text{ V}$		55	900	μA

Note 1: $T_a = 25^\circ\text{C}$, $DVCC2m = 2.5 \text{ V}$, $DVCC3n = 3.0 \text{ V}$, $AVCC3m = 3.3 \text{ V}$, unless otherwise noted.

Note 2: Measured with the CPU dhrystone operating, all I/O peripherals channel on, and 16-bit external bus operated with 4 system clocks.

Note 3: The supply current flowing through the $DVCC2m$, $FVCC2$, $DVCC3n$, $CVCC2$, $FVCC3$ and $AVCC3m$ pins is included in the digital supply current parameter (I_{CC}).

4.6 ADC Electrical Characteristics

DVCC15=CVCC15=1.5V ± 0.15V, DVCC2 = 2.5V ± 0.2V, DVCC3n = 3.0V ± 0.3V ,
 AVCC3m = 3.0V ± 0.2V Ta = 20 ~ 85 (n = 1 ~ 4, m = 1,2)

Parameter		Symbol	Condition	Min	Typ	Max	Unit
Analog reference voltage (+)		VREFH		2.7		3.3	V
				AVCCm-0.3	AVCC	AVCCm+0.3	
Analog reference voltage (-)		VREFL		AVSS	AVSS	AVSS + 0.2	
Analog input voltage		VAIN		VREFL		VREFH	
Analog supply current	During conversion ADMOD1.VREFON = 1	IREF	AVCCm = VREFH = 3.0V ± 0.3V DVSS = AVSS = VREFL		0.35	1.0	mA
	Not conversion ADMOD1.VREFON = 0		AVCCm = VREFH = 3.0V ± 0.3V DVSS = AVSS = VREFL		0.02	10	µA
Analog input capacitance		-			5.0		pF
Analog input impedance		-			5.0		k
Integral linearity error		-	AVCCm = VREFH = 3.0V ± 0.2V DVSS = AVSS = VREFL		±2	±3	LSB
Differential linearity error		-	AIN input impedance R < 13.3k C < 20pF		±1.5	±3	LSB
Off set error		-	AVCCm capacitor 10 µF VREFH capacitor 10 µF		±2	±3	LSB
Gain error		-	Conversion time 7.9 µs Note*		±2	±6	LSB

Note 1: 1 LSB = (VREFH – VREFL) / 1024 (V)

Note 2: The supply current flowing through the AVCC pin is included in the digital supply current parameter (ICC).

Note 3: Please shift to halt condition in AD converter before changing the standby mode of this product to STOP mode.

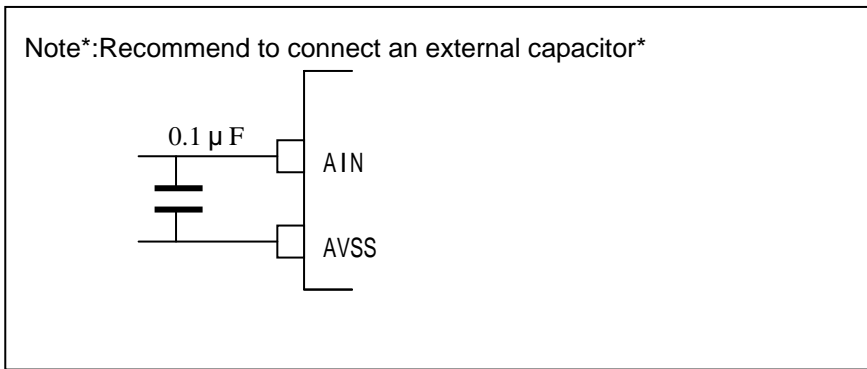

4.7 AC Electrical Characteristics

4.7.1 Multiplex Bus Mode

- (1) $DVCC2m = FVCC2 = CVCC2 = 2.5\text{ V} \pm 0.2\text{ V}$, $FVCC3 = 3.3\text{ V} \pm 0.3\text{ V}$,
 $AVCC3m = 3.3 \pm 0.2\text{ V}$, $DVCC33 = 3.0\text{ V} \pm 0.3\text{ V}$, $T_a = -20\text{ to }85^\circ\text{C}$ ($m = 1\text{ to }2$)

1. ALE width = 0.5 clock cycle, 1 programmed wait state

No.	Parameter	Symbol	Equation		40.5 MHz (fsys) (Note)		Unit
			Min	Max	Min	Max	
1	System clock period (x)	t_{SYS}	24.6				ns
2	A0-A15 valid to ALE low	t_{AL}	$0.5x - 4.3$		8		ns
3	A0-A15 hold after ALE low	t_{LA}	$0.5x - 1.8$		10.5		ns
4	ALE pulse width high	t_{LL}	$0.5x - 0.3$		12		ns
5	ALE low to \overline{RD} , \overline{WR} or \overline{HWR} asserted	t_{LC}	$0.5x - 2.3$		10		ns
6	\overline{RD} , \overline{WR} or \overline{HWR} negated to ALE high	t_{CL}	$x - 0.6$		24		ns
7	A0-A15 valid to \overline{RD} , \overline{WR} or \overline{HWR} asserted	t_{ACL}	$x - 5.1$		19.5		ns
8	A16-A23 valid to \overline{RD} , \overline{WR} or \overline{HWR} asserted	t_{ACH}	$x - 5.1$		19.5		ns
9	A16-A23 hold after \overline{RD} , \overline{WR} or \overline{HWR} negated	t_{CAR}	$x - 1.6$		23		ns
10	A0-A15 valid to D0-D15 Data in	t_{ADL}		$x(2 + W) - 35.8$		38	ns
11	A16-A23 valid to D0-D15 Data in	t_{ADH}		$x(2 + W) - 35.8$		38	ns
12	\overline{RD} asserted to D0-D15 data in	t_{RD}		$x(1 + W) - 30.7$		18.5	ns
13	\overline{RD} width low	t_{RR}	$x(1 + W) - 2.7$		46.5		ns
14	D0-D15 hold after \overline{RD} negated	t_{HR}	0		0		ns
15	\overline{RD} negated to next A0-A15 output	t_{RAE}	$x - 0.1$		24.5		ns
16	\overline{WR} or \overline{HWR} width low	t_{WW}	$x(1 + W) - 3.2$		46		ns
17	D0-D15 valid to \overline{WR} or \overline{HWR} negated	t_{DW}	$x(1 + W) - 4.2$		45		ns
18	D0-D15 hold after \overline{WR} or \overline{HWR} negated	t_{WD}	$x - 0.1$		24.5		ns
19	A16-A23 valid to \overline{WAIT} input	t_{AWH}		$x(3 + 0.5) - 21.6$		64.5	ns
20	A0-A15 valid to \overline{WAIT} input	t_{AWL}		$x(3 + 0.5) - 21.6$		64.5	ns
21	\overline{WAIT} hold after \overline{RD} , \overline{WR} or \overline{HWR} asserted	t_{CW}	$x(0.5 + 3 + N - 2) - 4.1$	$x(1.5 + 3 + N - 2) - 18.7$	57.4	67.4	ns

Note: No. 1 to 18 indicate the values obtained with 1 programmed wait state. NO. 19 and 20 indicate the values obtained with 4 externally generated wait states with $N = 1$.

AC measurement conditions:

- Output levels: High = $0.8DVCC33\text{ V}$ /Low $0.2DVCC33\text{ V}$, $CL = 30\text{ pF}$
- Input levels: High = $0.7DVCC33\text{ V}$ /Low $0.3DVCC33\text{ V}$

W: Number of wait state cycles inserted (0 to 7 for programmed wait insertion)

N: Value of N for (3 + N) wait insertion

2. ALE width = 1.5 clock cycles, 1 programmed wait state

No.	Parameter	Symbol	Equation		40.5 MHz (fsys) (Note)		Unit
			Min	Max	Min	Max	
1	System clock period (x)	t _{SYS}	24.6				ns
2	A0-A15 valid to ALE low	t _{AL}	1.5x – 3.9		33		ns
3	A0-A15 hold after ALE low	t _{LA}	0.5x – 1.8		10.5		ns
4	ALE pulse width high	t _{LL}	1.5x – 0.4		36.5		ns
5	ALE low to \overline{RD} , \overline{WR} or \overline{HWR} asserted	t _{LC}	0.5x – 2.4		10		ns
6	\overline{RD} , \overline{WR} or \overline{HWR} negated to ALE high	t _{CL}	x – 0.6		24		ns
7	A0-A15 valid to \overline{RD} , \overline{WR} or \overline{HWR} asserted	t _{ACL}	2x – 5.2		44		ns
8	A16-A23 valid to \overline{RD} , \overline{WR} or \overline{HWR} asserted	t _{ACH}	2x – 5.2		44		ns
9	A16-A23 hold after \overline{RD} , \overline{WR} or \overline{HWR} negated	t _{CAR}	x – 1.6		23		ns
10	A0-A15 valid to D0-D15 Data in	t _{ADL}		x (3 + W) – 35.9		62.5	ns
11	A16-A23 valid to D0-D15 Data in	t _{ADH}		x (3 + W) – 35.9		62.5	ns
12	\overline{RD} asserted to D0-D15 data in	t _{RD}		x (1 + W) – 30.7		18.5	ns
13	\overline{RD} width low	t _{RR}	x (1 + W) – 2.7		46.5		ns
14	D0-D15 hold after \overline{RD} negated	t _{HR}	0		0		ns
15	\overline{RD} negated to next A0-A15 output	t _{RAE}	x		24.6		ns
16	\overline{WR} or \overline{HWR} width low	t _{WW}	x (1 + W) – 3.2		46		ns
17	D0-D15 valid to \overline{WR} or \overline{HWR} negated	t _{DW}	x (1 + W) – 4.2		45		ns
18	D0-D15 hold after \overline{WR} or \overline{HWR} negated	t _{WD}	x – 0.1		24.5		ns
19	A16-A23 valid to \overline{WAIT} input	t _{AWH}		x (4 + 0.5) – 21.7		89	ns
20	A0-A15 valid to \overline{WAIT} input	t _{AWL}		x (4 + 0.5) – 21.7		89	ns
21	\overline{WAIT} hold after \overline{RD} , \overline{WR} or \overline{HWR} asserted	t _{CW}	x (0.5 + 3 + N – 2) – 4.1	x (1.5 + 3 + N – 2) – 18.7	57.4	67.4	ns

Note: No. 1 to 18 indicate the values obtained with 1 programmed wait state. NO. 19 and 20 indicate the values obtained with 4 externally generated wait states with N = 1.

AC measurement conditions:

- Output levels: High = 0.8DVCC33 V/Low 0.2DVCC33 V, CL = 30 pF
- Input levels: High = 0.7DVCC33 V/Low 0.3DVCC33 V

W: Number of wait state cycles inserted (0 to 7 for programmed wait insertion)

N: Value of N for (3 + N) wait insertion

- (2) $DVCC2m = FVCC2 = CVCC2 = 2.5\text{ V} \pm 0.2\text{ V}$, $FVCC3 = 3.3\text{ V} \pm 0.3\text{ V}$,
 $AVCC3m = 3.3 \pm 0.2\text{ V}$, $DVCC33 = 2.5\text{ V} \pm 0.2\text{ V}$, $T_a = 20\text{ to }85^\circ\text{C}$ ($m = 1\text{ to }2$)

1. ALE width = 0.5 clock cycle, 1 programmed wait state

No.	Parameter	Symbol	Equation		40.5 MHz (fsys) (Note)		Unit
			Min	Max	Min	Max	
1	System clock period (x)	t_{SYS}	24.6				ns
2	A0-A15 valid to ALE low	t_{AL}	$0.5x - 2.3$		10		ns
3	A0-A15 hold after ALE low	t_{LA}	$0.5x - 1.8$		10.5		ns
4	ALE pulse width high	t_{LL}	$0.5x - 0.3$		12		ns
5	ALE low to \overline{RD} , \overline{WR} or \overline{HWR} asserted	t_{LC}	$0.5x - 2.3$		10		ns
6	\overline{RD} , \overline{WR} or \overline{HWR} negated to ALE high	t_{CL}	$x - 0.6$		24		ns
7	A0-A15 valid to \overline{RD} , \overline{WR} or \overline{HWR} asserted	t_{ACL}	$x - 5.1$		19.5		ns
8	A16-A23 valid to \overline{RD} , \overline{WR} or \overline{HWR} asserted	t_{ACH}	$x - 5.1$		19.5		ns
9	A16-A23 hold after \overline{RD} , \overline{WR} or \overline{HWR} negated	t_{CAR}	$x - 1.6$		23		ns
10	A0-A15 valid to D0-D15 Data in	t_{ADL}		$x(2 + W) - 36.8$		37	ns
11	A16-A23 valid to D0-D15 Data in	t_{ADH}		$x(2 + W) - 36.8$		37	ns
12	\overline{RD} asserted to D0-D15 data in	t_{RD}		$x(1 + W) - 31.7$		17.5	ns
13	\overline{RD} width low	t_{RR}	$x(1 + W) - 2.2$		47		ns
14	D0-D15 hold after \overline{RD} negated	t_{HR}	0		0		ns
15	\overline{RD} negated to next A0-A15 output	t_{RAE}	$x - 0.1$		24.5		ns
16	\overline{WR} or \overline{HWR} width low	t_{WW}	$x(1 + W) - 2.7$		46.5		ns
17	D0-D15 valid to \overline{WR} or \overline{HWR} negated	t_{DW}	$x(1 + W) - 3.8$		45.5		ns
18	D0-D15 hold after \overline{WR} or \overline{HWR} negated	t_{WD}	$x - 0.1$		24.5		ns
19	A16-A23 valid to \overline{WAIT} input	t_{AWH}		$x(3 + 0.5) - 22.6$		63.5	ns
20	A0-A15 valid to \overline{WAIT} input	t_{AWL}		$x(3 + 0.5) - 22.6$		63.5	ns
21	\overline{WAIT} hold after \overline{RD} , \overline{WR} or \overline{HWR} asserted	t_{CW}	$x(0.5 + 3 + N - 2) - 5.1$	$x(1.5 + 3 + N - 2) - 19.7$	56.4	66.4	ns

Note: No. 1 to 18 indicate the values obtained with 1 programmed wait state. NO. 19 and 20 indicate the values obtained with 4 externally generated wait states with $N = 1$.

AC measurement conditions:

- Output levels: High = $0.8DVCC33\text{ V}$ /Low $0.2DVCC33\text{ V}$, $CL = 30\text{ pF}$
- Input levels: High = $0.7DVCC33\text{ V}$ /Low $0.3DVCC33\text{ V}$

W: Number of wait state cycles inserted (0 to 7 for programmed wait insertion)

N: Value of N for (3 + N) wait insertion

2. ALE width = 1.5 clock cycles, 1 programmed wait state

No.	Parameter	Symbol	Equation		40.5 MHz (fsys) (Note)		Unit
			Min	Max	Min	Max	
1	System clock period (x)	t _{SYS}	24.6				ns
2	A0-A15 valid to ALE low	t _{AL}	1.5x – 2.4		34.5		ns
3	A0-A15 hold after ALE low	t _{LA}	0.5x – 1.8		10.5		ns
4	ALE pulse width high	t _{LL}	1.5x – 0.4		36.5		ns
5	ALE low to \overline{RD} , \overline{WR} or \overline{HWR} asserted	t _{LC}	0.5x – 2.4		10		ns
6	\overline{RD} , \overline{WR} or \overline{HWR} negated to ALE high	t _{CL}	x – 0.6		24		ns
7	A0-A15 valid to \overline{RD} , \overline{WR} or \overline{HWR} asserted	t _{ACL}	2x – 5.2		44		ns
8	A16-A23 valid to \overline{RD} , \overline{WR} or \overline{HWR} asserted	t _{ACH}	2x – 5.2		44		ns
9	A16-A23 hold after \overline{RD} , \overline{WR} or \overline{HWR} negated	t _{CAR}	x – 1.6		23		ns
10	A0-A15 valid to D0-D15 Data in	t _{ADL}		x (3 + W) – 36.9		61.5	ns
11	A16-A23 valid to D0-D15 Data in	t _{ADH}		x (3 + W) – 36.9		61.5	ns
12	\overline{RD} asserted to D0-D15 data in	t _{RD}		x (1 + W) – 31.7		17.5	ns
13	\overline{RD} width low	t _{RR}	x (1 + W) – 2.2		47		ns
14	D0-D15 hold after \overline{RD} negated	t _{HR}	0		0		ns
15	\overline{RD} negated to next A0-A15 output	t _{RAE}	x – 0.1		24.5		ns
16	\overline{WR} or \overline{HWR} width low	t _{WW}	x (1 + W) – 2.7		46.5		ns
17	D0-D15 valid to \overline{WR} or \overline{HWR} negated	t _{DW}	x (1 + W) – 3.8		45.5		ns
18	D0-D15 hold after \overline{WR} or \overline{HWR} negated	t _{WD}	x – 0.1		24.5		ns
19	A16-A23 valid to \overline{WAIT} input	t _{AWH}		x (4 + 0.5) – 22.6		88.1	ns
20	A0-A15 valid to \overline{WAIT} input	t _{AWL}		x (4 + 0.5) – 22.6		88.1	ns
21	\overline{WAIT} hold after \overline{RD} , \overline{WR} or \overline{HWR} asserted	t _{CW}	x (0.5 + 3 + N – 2) – 5.1	x (1.5 + 3 + N – 2) – 19.7	56.4	66.4	ns

Note: No. 1 to 18 indicate the values obtained with 1 programmed wait state. NO. 19 and 20 indicate the values obtained with 4 externally generated wait states with N = 1.

AC measurement conditions:

- Output levels: High = 0.8DVCC33 V/Low 0.2DVCC33 V, CL = 30 pF
- Input levels: High = 0.7DVCC33 V/Low 0.3DVCC33 V

W: Number of wait state cycles inserted (0 to 7 for programmed wait insertion)

N: Value of N for (3 + N) wait insertion

- (3) $DVCC2m = FVCC2 = CVCC2 = 2.5\text{ V} \pm 0.2\text{ V}$, $FVCC3 = 3.3\text{ V} \pm 0.3\text{ V}$,
 $AVCC3m = 3.3 \pm 0.2\text{ V}$, $DVCC33 = 1.8\text{ V} \pm 0.15\text{ V}$, $T_a = 20\text{ to }85^\circ\text{C}$ ($m = 1\text{ to }2$)

1. ALE width = 0.5 clock cycle, 2 programmed wait state

No.	Parameter	Symbol	Equation		40.5 MHz (fsys) (Note)		Unit
			Min	Max	Min	Max	
1	System clock period (x)	t_{SYS}	24.6	33333			ns
2	A0-A15 valid to ALE low	t_{AL}	$0.5x - 2.3$		10		ns
3	A0-A15 hold after ALE low	t_{LA}	$0.5x - 1.8$		10.5		ns
4	ALE pulse width high	t_{LL}	$0.5x - 0.3$		12		ns
5	ALE low to \overline{RD} , \overline{WR} or \overline{HWR} asserted	t_{LC}	$0.5x - 2.3$		10		ns
6	\overline{RD} , \overline{WR} or \overline{HWR} negated to ALE high	t_{CL}	$x - 0.6$		24		ns
7	A0-A15 valid to \overline{RD} , \overline{WR} or \overline{HWR} asserted	t_{ACL}	$x - 5.1$		19.5		ns
8	A16-A23 valid to \overline{RD} , \overline{WR} or \overline{HWR} asserted	t_{ACH}	$x - 5.1$		19.5		ns
9	A16-A23 hold after \overline{RD} , \overline{WR} or \overline{HWR} negated	t_{CAR}	$x - 1.6$		23		ns
10	A0-A15 valid to D0-D15 Data in	t_{ADL}		$x(2+W) - 42.4$		56	ns
11	A16-A23 valid to D0-D15 Data in	t_{ADH}		$x(2+W) - 42.4$		56	ns
12	\overline{RD} asserted to D0-D15 data in	t_{RD}		$x(1+W) - 37.3$		36.5	ns
13	\overline{RD} width low	t_{RR}	$x(1+W) - 2.3$		71.5		ns
14	D0-D15 hold after \overline{RD} negated	t_{HR}	0		0		ns
15	\overline{RD} negated to next A0-A15 output	t_{RAE}	$x - 0.1$		24.5		ns
16	\overline{WR} or \overline{HWR} width low	t_{WW}	$x(1+W) - 2.8$		71		ns
17	D0-D15 valid to \overline{WR} or \overline{HWR} negated	t_{DW}	$x(1+W) - 3.8$		70		ns
18	D0-D15 hold after \overline{WR} or \overline{HWR} negated	t_{WD}	$x - 0.1$		24.5		ns
19	A16-A23 valid to \overline{WAIT} input	t_{AWH}		$x(3+0.5) - 28.1$		58	ns
20	A0-A15 valid to \overline{WAIT} input	t_{AWL}		$x(3+0.5) - 28.1$		58	ns
21	\overline{WAIT} hold after \overline{RD} , \overline{WR} or \overline{HWR} asserted	t_{CW}	$x(0.5+3+N) - 2$ - 6.1	$x(1.5+3+N) - 2$ - 24.7	55.4	61.4	ns

Note: No. 1 to 18 indicate the values obtained with 1 programmed wait state. NO. 19 and 20 indicate the values obtained with 4 externally generated wait states with $N = 1$.

AC measurement conditions:

- Output levels: High = $0.8DVCC33\text{ V}$ /Low $0.2DVCC33\text{ V}$, $CL = 30\text{ pF}$
- Input levels: High = $0.7DVCC33\text{ V}$ /Low $0.3DVCC33\text{ V}$

W: Number of wait state cycles inserted (0 to 7 for programmed wait insertion)

N: Value of N for $(3+N)$ wait insertion

2. ALE width = 1.5 clock cycles, 2 programmed wait states

No.	Parameter	Symbol	Equation		40.5 MHz (fsys) (Note)		Unit
			Min	Max	Min	Max	
1	System clock period (x)	t _{SYS}	24.6				ns
2	A0-A15 valid to ALE low	t _{AL}	1.5x – 2.4		34.5		ns
3	A0-A15 hold after ALE low	t _{LA}	0.5x – 1.8		10.5		ns
4	ALE pulse width high	t _{LL}	1.5x – 0.4		36.5		ns
5	ALE low to \overline{RD} , \overline{WR} or \overline{HWR} asserted	t _{LC}	0.5x – 2.3		10		ns
6	\overline{RD} , \overline{WR} or \overline{HWR} negated to ALE high	t _{CL}	x – 0.6		24		ns
7	A0-A15 valid to \overline{RD} , \overline{WR} or \overline{HWR} asserted	t _{ACL}	2x – 5.2		44		ns
8	A16-A23 valid to \overline{RD} , \overline{WR} or \overline{HWR} asserted	t _{ACH}	2x – 5.2		44		ns
9	A16-A23 hold after \overline{RD} , \overline{WR} or \overline{HWR} negated	t _{CAR}	x – 1.6		23		ns
10	A0-A15 valid to D0-D15 Data in	t _{ADL}		x (3 + W) – 42.5		80.5	ns
11	A16-A23 valid to D0-D15 Data in	t _{ADH}		x (3 + W) – 42.5		80.5	ns
12	\overline{RD} asserted to D0-D15 data in	t _{RD}		x (1 + W) – 37.3		36.5	ns
13	\overline{RD} width low	t _{RR}	x (1 + W) – 2.3		71.5		ns
14	D0-D15 hold after \overline{RD} negated	t _{HR}	0		0		ns
15	\overline{RD} negated to next A0-A15 output	t _{RAE}	x – 0.1		24.5		ns
16	\overline{WR} or \overline{HWR} width low	t _{WW}	x (1 + W) – 2.8		71		ns
17	D0-D15 valid to \overline{WR} or \overline{HWR} negated	t _{DW}	x (1 + W) – 3.8		70		ns
18	D0-D15 hold after \overline{WR} or \overline{HWR} negated	t _{WD}	x – 0.1		24.5		ns
19	A16-A23 valid to \overline{WAIT} input	t _{AWH}		x (4 + 0.5) – 28.1		82.6	ns
20	A0-A15 valid to \overline{WAIT} input	t _{AWL}		x (4 + 0.5) – 28.1		82.6	ns
21	\overline{WAIT} hold after \overline{RD} , \overline{WR} or \overline{HWR} asserted	t _{CW}	x (0.5 + 3 + N – 2) – 6.1	x (1.5 + 3 + N – 2) – 24.7	55.4	61.4	ns

Note: No. 1 to 18 indicate the values obtained with 1 programmed wait state. NO. 19 and 20 indicate the values obtained with 4 externally generated wait states with N = 1.

AC measurement conditions:

- Output levels: High = 0.8DVCC33 V/Low 0.2DVCC33 V, CL = 30 pF
- Input levels: High = 0.7DVCC33 V/Low 0.3DVCC33 V

W: Number of wait state cycles inserted (0 to 7 for programmed wait insertion)

N: Value of N for (3 + N) wait insertion

(1) Read cycle timing, ALE width = 0.5 clock cycle, 1 programmed wait state

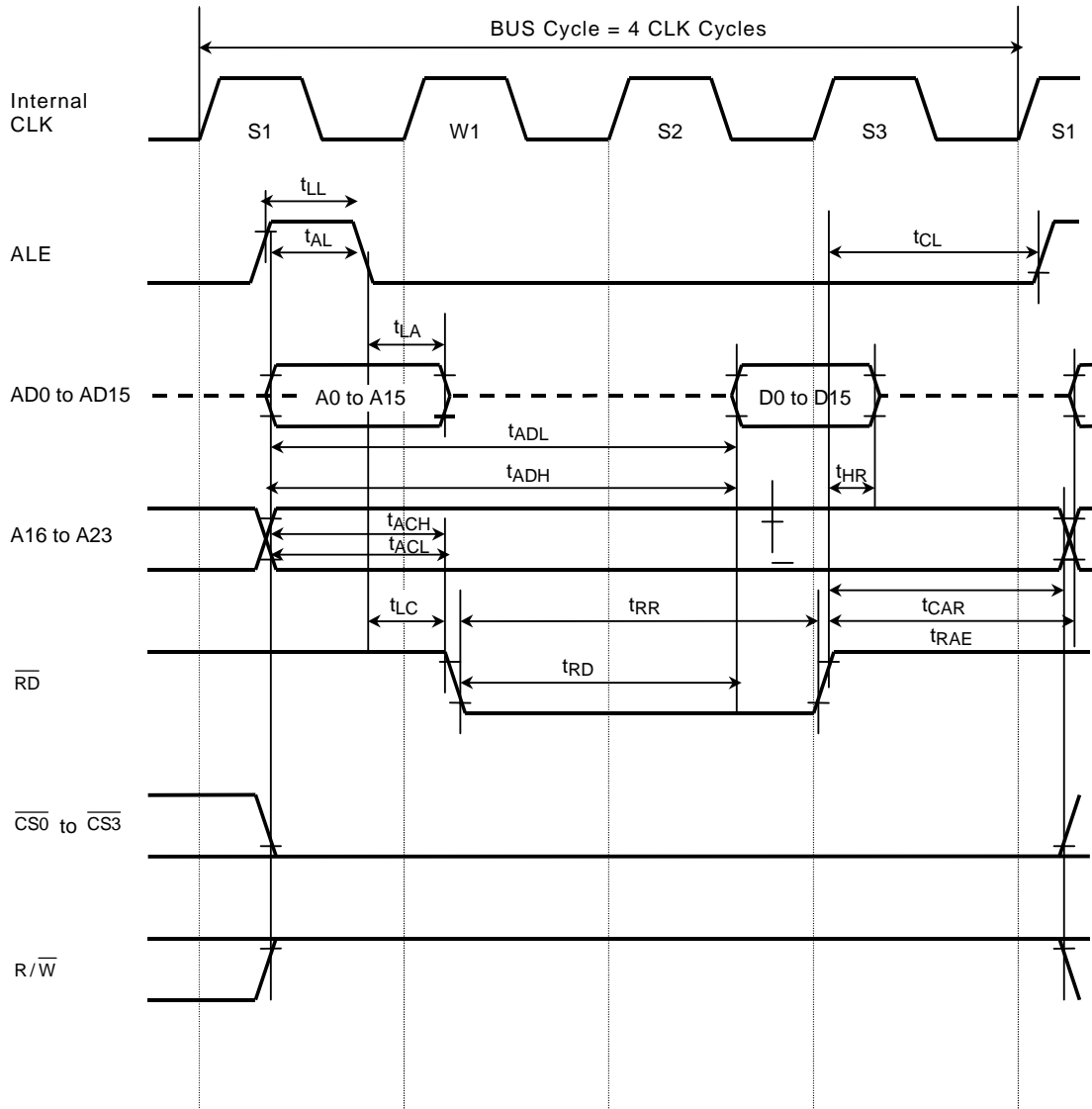

(2) Read cycle timing, ALE width = 1.5 clock cycles, 1 programmed wait state

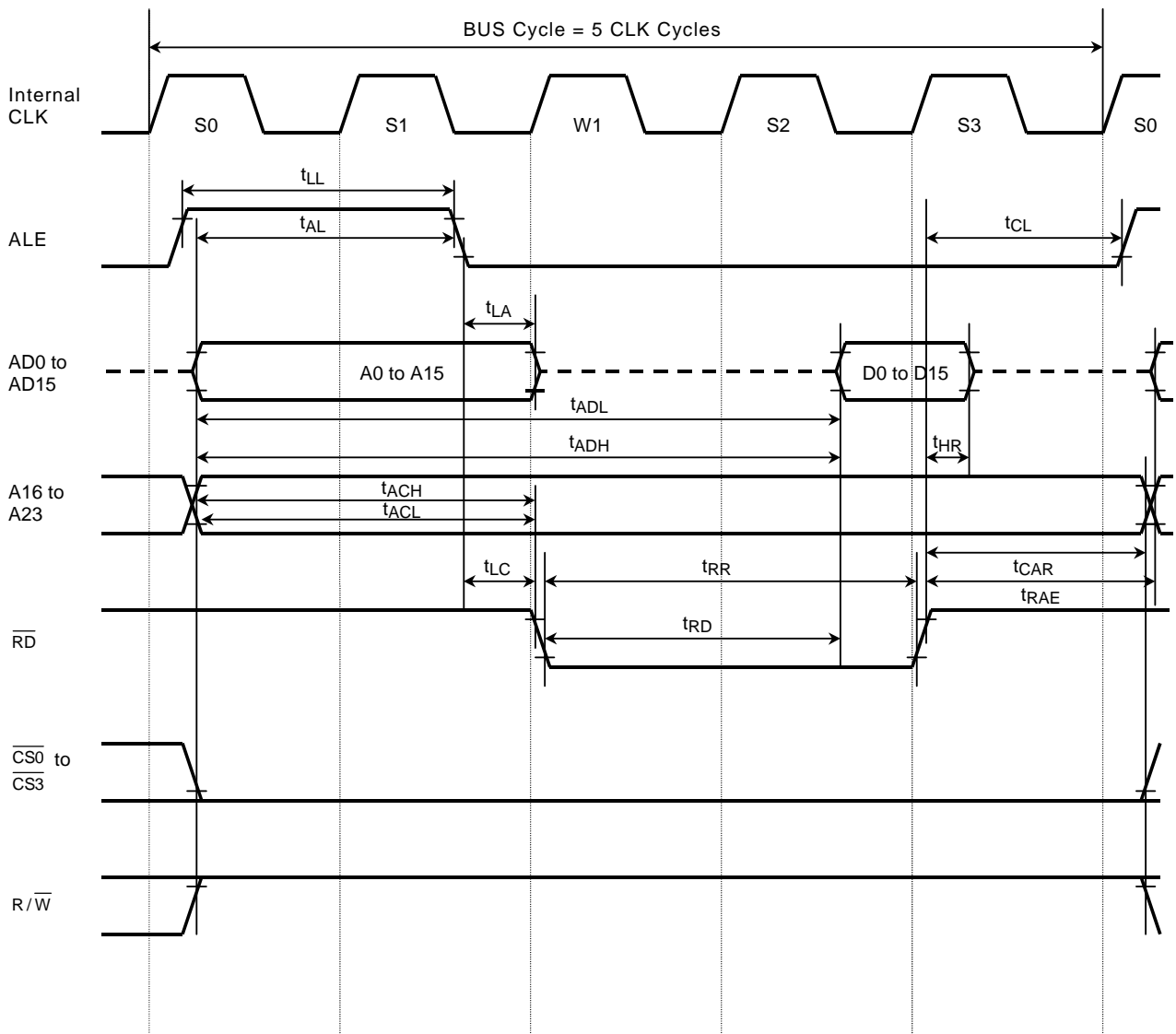

(3) Read cycle timing, ALE width = 1.5 clock cycles, 2 externally generated wait states with N = 1

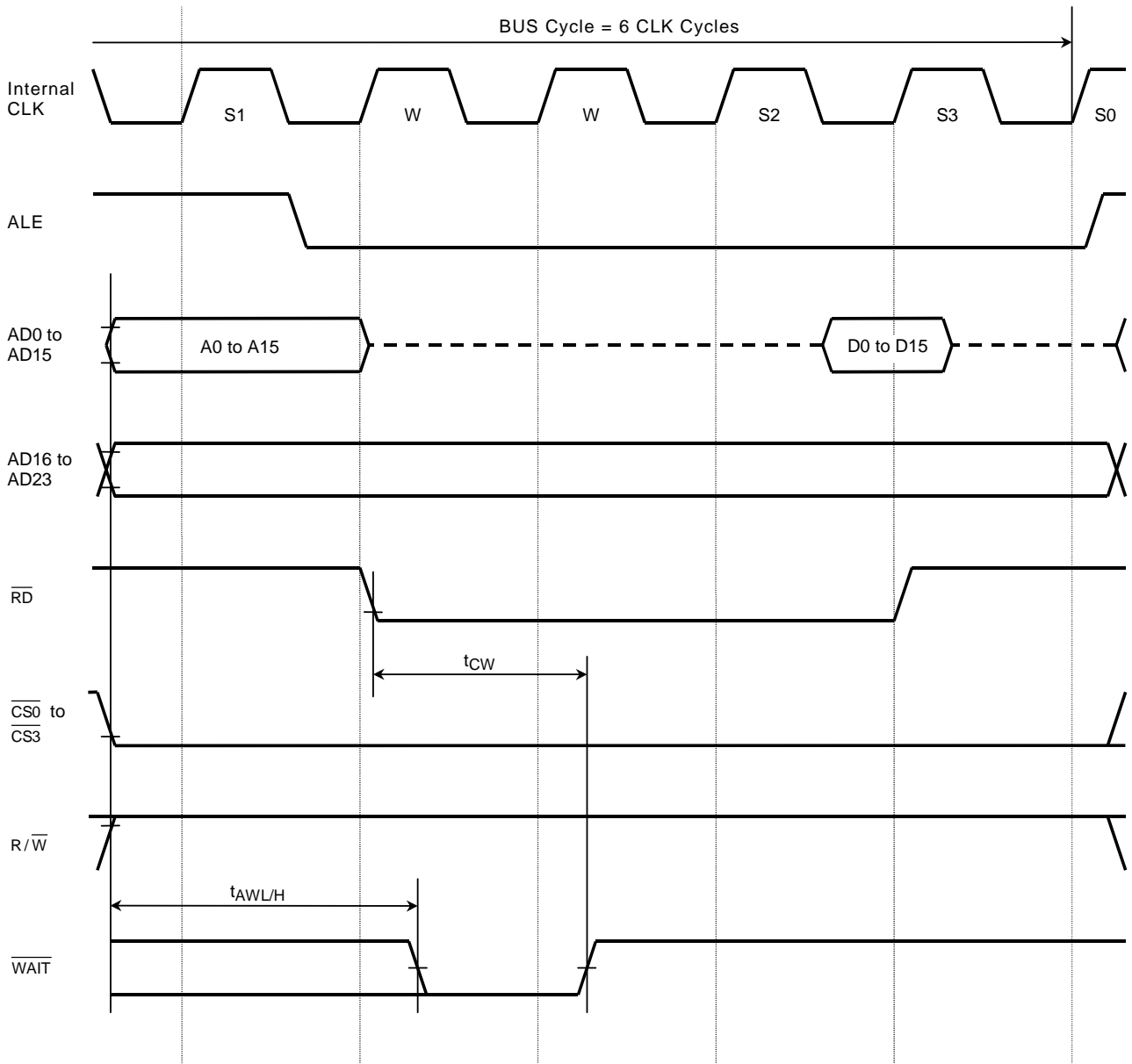

(4) Read cycle timing, ALE width = 1.5 clock cycles, 4 externally generated wait states with N = 1

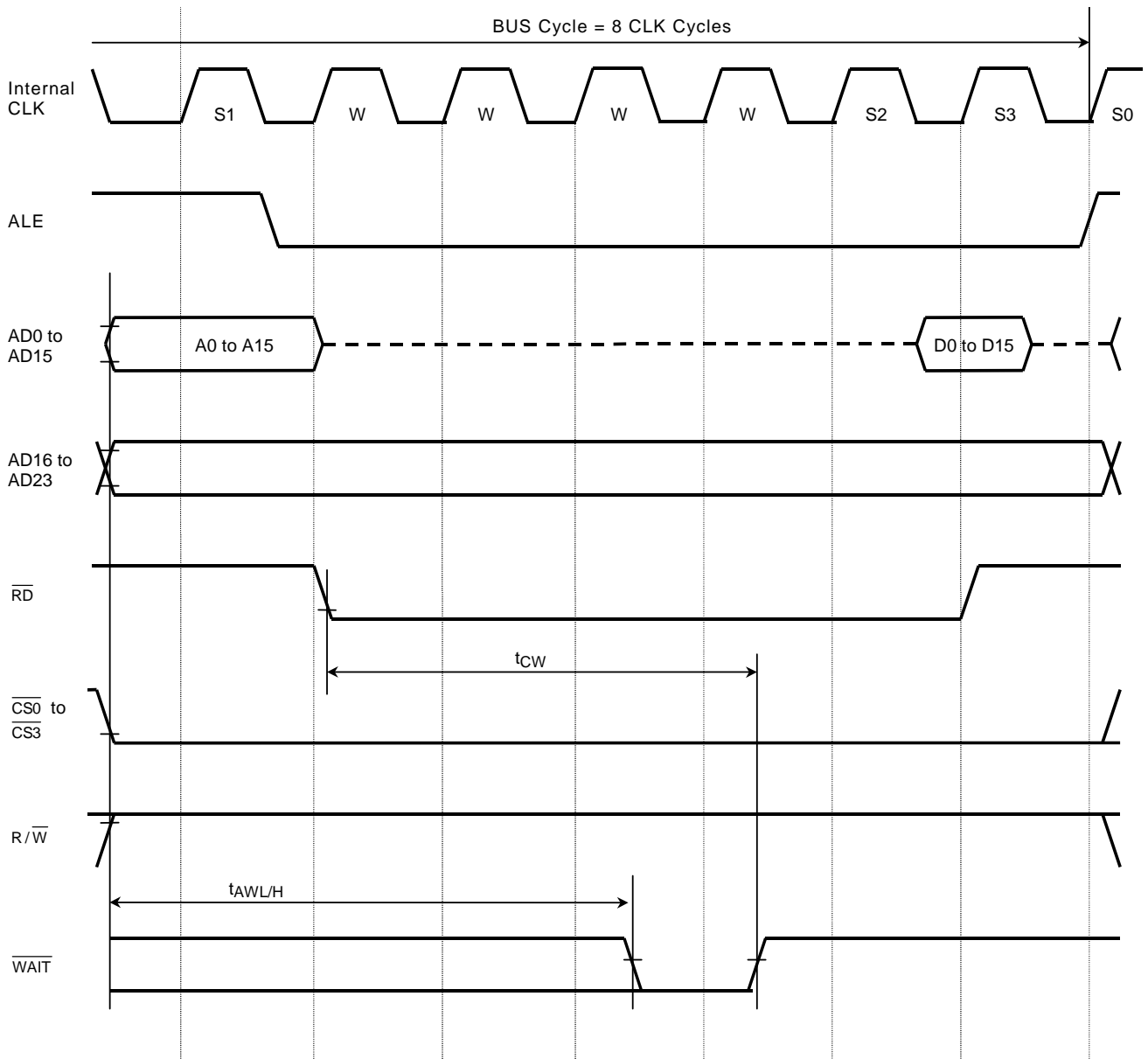

(5) Write cycle timing, ALE width = 1.5 clock cycles, zero wait state

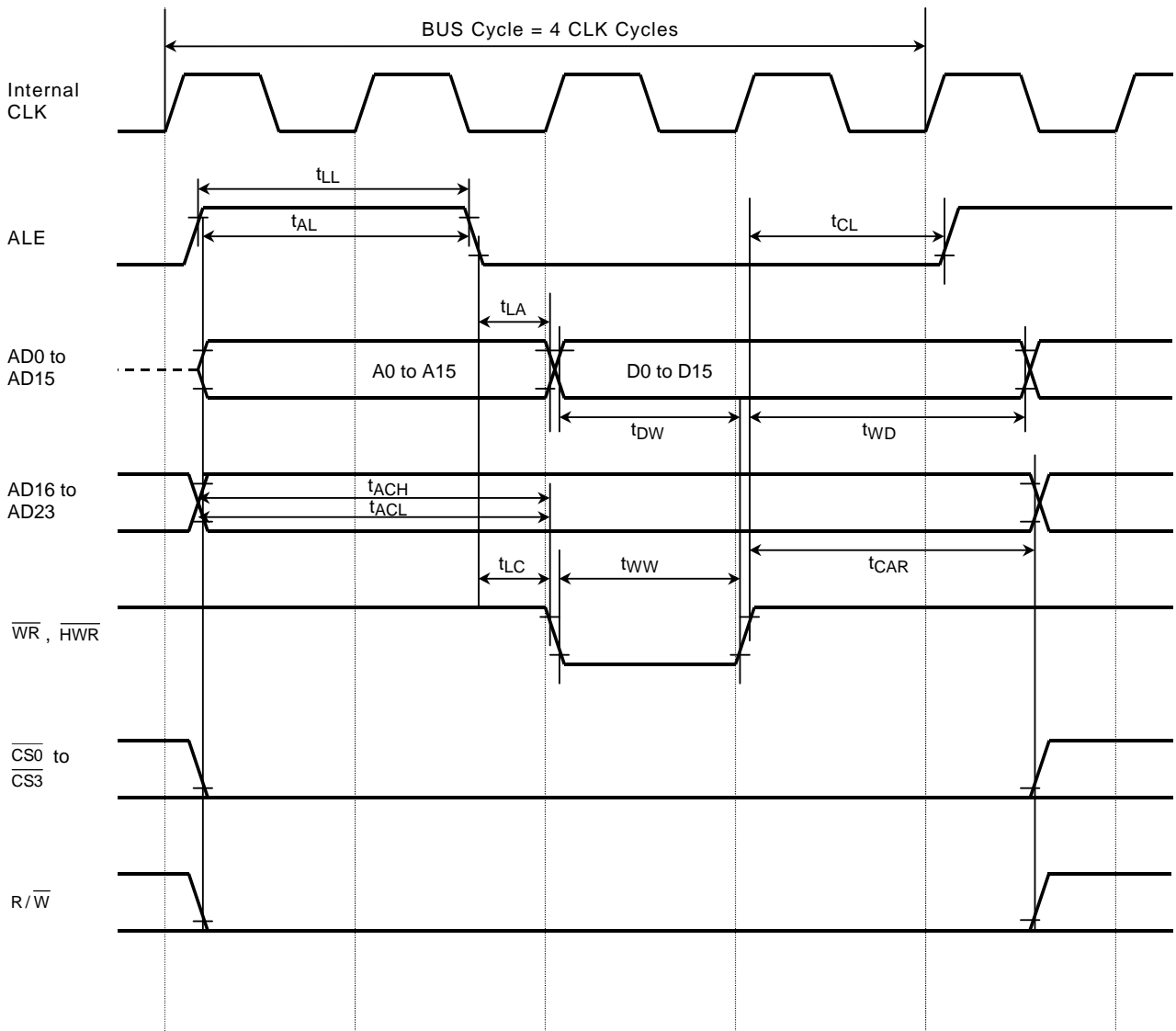

4.7.2 Separate Bus Mode

- (1) $DVCC2m = FVCC2 = CVCC2 = 2.5\text{ V} \pm 0.2\text{ V}$, $FVCC3 = 3.3\text{ V} \pm 0.3\text{ V}$,
 $AVCC3m = 3.3 \pm 0.2\text{ V}$, $DVCC33 = 3.0\text{ V} \pm 0.3\text{ V}$, $T_a = -20\text{ to }85^\circ\text{C}$ ($m = 1\text{ to }2$)

1. SYSCR3<ALESEL> = 0, 1 programmed wait state

No.	Parameter	Symbol	Equation		40.5 MHz (fsys) (Note)		Unit
			Min	Max	Min	Max	
1	System clock period (x)	t _{SYS}	24.6				ns
2	A0-A23 valid to \overline{RD} , \overline{WR} or \overline{HWR} asserted	t _{AC}	x - 5.1		19.5		ns
3	A0-A23 hold after \overline{RD} , \overline{WR} or \overline{HWR} negated	t _{CAR}	x - 1.6		23		ns
4	A0-A23 valid to D0-D15 Data in	t _{AD}		x (2 + W) - 35.8		38	ns
5	\overline{RD} asserted to D0-D15 data in	t _{RD}		x (1 + W) - 30.7		18.5	ns
6	\overline{RD} width low	t _{RR}	x (1 + W) - 2.7		46.5		ns
7	D0-D15 hold after \overline{RD} negated	t _{HR}	0		0		ns
8	\overline{RD} negated to next A0-A23 output	t _{RAE}	x - 0.1		24.5		ns
9	\overline{WR} or \overline{HWR} width low	t _{WW}	x (1 + W) - 3.2		46		ns
10	\overline{WR} or \overline{HWR} asserted to D0-D15 valid	t _{DO}		—		1	ns
11	D0-D15 valid to \overline{WR} or \overline{HWR} negated	t _{DW}	x (1 + W) - 4.2		45		ns
12	D0-D15 hold after \overline{WR} or \overline{HWR} negated	t _{WD}	x - 0.1		24.5		ns
13	A0-A23 valid to \overline{WAIT} input	t _{AW}		x (3 + 0.5) - 21.6		64.5	ns
14	\overline{WAIT} hold after \overline{RD} , \overline{WR} or \overline{HWR} asserted	t _{CW}	x (0.5 + 3 + N - 2) - 4.1	x (1.5 + 3 + N - 2) - 18.7	57.4	67.4	ns

Note: No. 1 to 12 indicate the values obtained with 1 programmed wait state. NO. 13 and 14 indicate the values obtained with 4 externally generated wait states with N = 1.

AC measurement conditions:

- Output levels: High = 0.8DVCC33 V/Low 0.2DVCC33 V, CL = 30 pF
- Input levels: High = 0.7DVCC33 V/Low 0.3DVCC33 V

W: Number of wait state cycles inserted (0 to 7 for programmed wait insertion)

N: Value of N for (3 + N) wait insertion

2. SYSCR3<ALESEL> = 1, 1 programmed wait state

No.	Parameter	Symbol	Equation		40.5 MHz (fsys) (Note)		Unit
			Min	Max	Min	Max	
1	System clock period (x)	t _{SYS}	24.6				ns
2	A0-A23 valid to \overline{RD} , \overline{WR} or \overline{HWR} asserted	t _{AC}	$2x - 5.2$		44		ns
3	A0-A23 hold after \overline{RD} , \overline{WR} or \overline{HWR} negated	t _{CAR}	$x - 1.6$		23		ns
4	A0-A23 valid to D0-D15 Data in	t _{AD}		$x(3 + W) - 35.9$		62.5	ns
5	\overline{RD} asserted to D0-D15 data in	t _{RD}		$x(1 + W) - 30.7$		18.5	ns
6	\overline{RD} width low	t _{RR}	$x(1 + W) - 2.7$		46.5		ns
7	D0-D15 hold after \overline{RD} negated	t _{HR}	0		0		ns
8	\overline{RD} negated to next A0-A23 output	t _{RAE}	x		24.6		ns
9	\overline{WR} or \overline{HWR} width low	t _{WW}	$x(1 + W) - 3.2$		46		ns
10	\overline{WR} or \overline{HWR} asserted to D0-D15 valid	t _{DO}		—		1	ns
11	D0-D15 valid to \overline{WR} or \overline{HWR} negated	t _{DW}	$x(1 + W) - 4.2$		45		ns
12	D0-D15 hold after \overline{WR} or \overline{HWR} negated	t _{WD}	$x - 0.1$		24.5		ns
13	A0-A23 valid to \overline{WAIT} input	t _{AW}		$x(4 + 0.5) - 21.7$		89	ns
14	\overline{WAIT} hold after \overline{RD} , \overline{WR} or \overline{HWR} asserted	t _{CW}	$x(0.5 + 3 + N - 2) - 4.1$	$x(1.5 + 3 + N - 2) - 18.7$	57.4	67.4	ns

Note: No. 1 to 12 indicate the values obtained with 1 programmed wait state. NO. 13 and 14 indicate the values obtained with 4 externally generated wait states with N = 1.

AC measurement conditions:

- Output levels: High = 0.8DVCC33 V/Low 0.2DVCC33 V, CL = 30 pF
- Input levels: High = 0.7DVCC33 V/Low 0.3DVCC33 V

W: Number of wait state cycles inserted (0 to 7 for programmed wait insertion)

N: Value of N for (3 + N) wait insertion

- (2) $DVCC2m = FVCC2 = CVCC2 = 2.5\text{ V} \pm 0.2\text{ V}$, $FVCC3 = 3.3\text{ V} \pm 0.3\text{ V}$,
 $AVCC3m = 3.3 \pm 0.2\text{ V}$, $DVCC33 = 2.5\text{ V} \pm 0.2\text{ V}$, $T_a = -20\text{ to }85^\circ\text{C}$ ($m = 1\text{ to }2$)

1. SYSCR3<ALESEL> = 0, 1 programmed wait state

No.	Parameter	Symbol	Equation		40.5 MHz (fsys) (Note)		Unit
			Min	Max	Min	Max	
1	System clock period (x)	t_{SYS}	24.6				ns
2	A0-A23 valid to \overline{RD} , \overline{WR} or \overline{HWR} asserted	t_{AC}	$x - 5.1$		19.5		ns
3	A0-A23 hold after \overline{RD} , \overline{WR} or \overline{HWR} negated	t_{CAR}	$x - 1.6$		23		ns
4	A16-A23 valid to D0-D15 Data in	t_{AD}		$x(2 + W) - 36.8$		37	ns
5	\overline{RD} asserted to D0-D15 data in	t_{RD}		$x(1 + W) - 31.7$		17.5	ns
6	\overline{RD} width low	t_{RR}	$x(1 + W) - 2.2$		47		ns
7	D0-D15 hold after \overline{RD} negated	t_{HR}	0		0		ns
8	\overline{RD} negated to next A0-A23 output	t_{RAE}	$x - 0.1$		24.5		ns
9	\overline{WR} or \overline{HWR} width low	t_{WW}	$x(1 + W) - 2.7$		46.5		ns
10	\overline{WR} or \overline{HWR} asserted to D0-D15 valid	t_{DO}		—		1.5	ns
11	D0-D15 valid to \overline{WR} or \overline{HWR} negated	t_{DW}	$x(1 + W) - 3.8$		45.5		ns
12	D0-D15 hold after \overline{WR} or \overline{HWR} negated	t_{WD}	$x - 0.1$		24.5		ns
13	A0-A23 valid to \overline{WAIT} input	t_{AW}		$x(3 + 0.5) - 22.6$		63.5	ns
14	\overline{WAIT} hold after \overline{RD} , \overline{WR} or \overline{HWR} asserted	t_{CW}	$x(0.5 + 3 + N - 2) - 5.1$	$x(1.5 + 3 + N - 2) - 19.7$	56.4	66.4	ns

Note: No. 1 to 12 indicate the values obtained with 1 programmed wait state. NO. 13 and 14 indicate the values obtained with 4 externally generated wait states with $N = 1$.

AC measurement conditions:

- Output levels: High = $0.8DVCC33\text{ V}$ /Low $0.2DVCC33\text{ V}$, $CL = 30\text{ pF}$
- Input levels: High = $0.7DVCC33\text{ V}$ /Low $0.3DVCC33\text{ V}$

W: Number of wait state cycles inserted (0 to 7 for programmed wait insertion)

N: Value of N for (3 + N) wait insertion

2. SYSCR3<ALESEL> = 1, 1 programmed wait state

No.	Parameter	Symbol	Equation		40.5 MHz (fsys) (Note)		Unit
			Min	Max	Min	Max	
1	System clock period (x)	t _{SYS}	24.6				ns
2	A0-A23 valid to \overline{RD} , \overline{WR} or \overline{HWR} asserted	t _{AC}	$2x - 5.2$		44		ns
3	A0-A23 hold after \overline{RD} , \overline{WR} or \overline{HWR} negated	t _{CAR}	$x - 1.6$		23		ns
4	A16-A23 valid to D0-D15 Data in	t _{AD}		$x(3 + W) - 36.9$		61.5	ns
5	\overline{RD} asserted to D0-D15 data in	t _{RD}		$x(1 + W) - 31.7$		17.5	ns
6	\overline{RD} width low	t _{RR}	$x(1 + W) - 2.2$		47		ns
7	D0-D15 hold after \overline{RD} negated	t _{HR}	0		0		ns
8	\overline{RD} negated to next A0-A23 output	t _{RAE}	$x - 0.1$		24.5		ns
9	\overline{WR} or \overline{HWR} width low	t _{WW}	$x(1 + W) - 2.7$		46.5		ns
10	\overline{WR} or \overline{HWR} asserted to D0-D15 valid	t _{DO}		—		1.5	ns
11	D0-D15 valid to \overline{WR} or \overline{HWR} negated	t _{DW}	$x(1 + W) - 3.8$		45.5		ns
12	D0-D15 hold after \overline{WR} or \overline{HWR} negated	t _{WD}	$x - 0.1$		24.5		ns
13	A0-A23 valid to \overline{WAIT} input	t _{AW}		$x(4 + 0.5) - 22.6$		88.1	ns
14	\overline{WAIT} hold after \overline{RD} , \overline{WR} or \overline{HWR} asserted	t _{CW}	$x(0.5 + 3 + N - 2) - 5.1$	$x(1.5 + 3 + N - 2) - 19.7$	56.4	66.4	ns

Note: No. 1 to 12 indicate the values obtained with 1 programmed wait state. NO. 13 and 14 indicate the values obtained with 4 externally generated wait states with N = 1.

AC measurement conditions:

- Output levels: High = 0.8DVCC33 V/Low 0.2DVCC33 V, CL = 30 pF
- Input levels: High = 0.7DVCC33 V/Low 0.3DVCC33 V

W: Number of wait state cycles inserted (0 to 7 for programmed wait insertion)

N: Value of N for (3 + N) wait insertion

- (3) $DVCC2m = FVCC2 = CVCC2 = 2.5\text{ V} \pm 0.2\text{ V}$, $FVCC3 = 3.3\text{ V} \pm 0.3\text{ V}$,
 $AVCC3m = 3.3 \pm 0.2\text{ V}$, $DVCC33 = 1.8\text{ V} \pm 0.15\text{ V}$, $T_a = -20\text{ to }85^\circ\text{C}$ ($m = 1\text{ to }2$)

1. SYSCR3<ALESEL> = 0, 2 programmed wait states

No.	Parameter	Symbol	Equation		40.5 MHz (fsys) (Note)		Unit
			Min	Max	Min	Max	
1	System clock period (x)	t_{SYS}	24.6				ns
2	A0-A23 valid to \overline{RD} , \overline{WR} or \overline{HWR} asserted	t_{AC}	$x - 5.1$		19.5		ns
3	A0-A23 hold after \overline{RD} , \overline{WR} or \overline{HWR} negated	t_{CAR}	$x - 1.6$		23		ns
4	A0-A23 valid to D0-D15 Data in	t_{AD}		$x(2 + W) - 42.4$		56	ns
5	\overline{RD} asserted to D0-D15 data in	t_{RD}		$x(1 + W) - 37.3$		36.5	ns
6	\overline{RD} width low	t_{RR}	$x(1 + W) - 2.3$		71.5		ns
7	D0-D15 hold after \overline{RD} negated	t_{HR}	0		0		ns
8	\overline{RD} negated to next A0-A23 output	t_{RAE}	$x - 0.1$		24.5		ns
9	\overline{WR} or \overline{HWR} width low	t_{WW}	$x(1 + W) - 2.8$		71		ns
10	\overline{WR} or \overline{HWR} asserted to D0-D15 valid	t_{DO}		—		2	ns
11	D0-D15 valid to \overline{WR} or \overline{HWR} negated	t_{DW}	$x(1 + W) - 3.8$		70		ns
12	D0-D15 hold after \overline{WR} or \overline{HWR} negated	t_{WD}	$x - 0.1$		24.5		ns
13	A0-A23 valid to \overline{WAIT} input	t_{AWH}		$x(3 + 0.5) - 28.1$		58	ns
14	\overline{WAIT} hold after \overline{RD} , \overline{WR} or \overline{HWR} asserted	t_{CW}	$x(0.5 + 3 + N - 2) - 6.1$	$x(1.5 + 3 + N - 2) - 24.7$	55.4	61.4	ns

Note: No. 1 to 12 indicate the values obtained with 1 programmed wait state. NO. 13 and 14 indicate the values obtained with 4 externally generated wait states with $N = 1$.

AC measurement conditions:

- Output levels: High = $0.8DVCC33\text{ V}$ /Low $0.2DVCC33\text{ V}$, $CL = 30\text{ pF}$
- Input levels: High = $0.7DVCC33\text{ V}$ /Low $0.3DVCC33\text{ V}$

W: Number of wait state cycles inserted (0 to 7 for programmed wait insertion)

N: Value of N for (3 + N) wait insertion

2. SYSCR3<ALESEL> = 1, 2 programmed states

No.	Parameter	Symbol	Equation		40.5 MHz (fsys) (Note)		Unit
			Min	Max	Min	Max	
1	System clock period (x)	t _{SYS}	24.6				ns
2	A0-A23 valid to \overline{RD} , \overline{WR} or \overline{HWR} asserted	t _{AC}	$2x - 5.2$		44		ns
3	A0-A23 hold after \overline{RD} , \overline{WR} or \overline{HWR} negated	t _{CAR}	$x - 1.6$		23		ns
4	A16-A23 valid to D0-D15 Data in	t _{AD}		$x(3 + W) - 42.5$		80.5	ns
5	\overline{RD} asserted to D0-D15 data in	t _{RD}		$x(1 + W) - 37.3$		36.5	ns
6	\overline{RD} width low	t _{RR}	$x(1 + W) - 2.3$		71.5		ns
7	D0-D15 hold after \overline{RD} negated	t _{HR}	0		0		ns
8	\overline{RD} negated to next A0-A23 output	t _{RAE}	$x - 0.1$		24.5		ns
9	\overline{WR} or \overline{HWR} width low	t _{WW}	$x(1 + W) - 2.8$		71		ns
10	\overline{WR} or \overline{HWR} asserted to D0-D15 valid	t _{DO}		—		2	ns
11	D0-D15 valid to \overline{WR} or \overline{HWR} negated	t _{DW}	$x(1 + W) - 3.8$		70		ns
12	D0-D15 hold after \overline{WR} or \overline{HWR} negated	t _{WD}	$x - 0.1$		24.5		ns
13	A0-A23 valid to \overline{WAIT} input	t _{AWH}		$x(4 + 0.5) - 28.1$		82.6	ns
14	\overline{WAIT} hold after \overline{RD} , \overline{WR} or \overline{HWR} asserted	t _{CW}	$x(0.5 + 3 + N) - 6.1$	$x(1.5 + 3 + N) - 24.7$	55.4	61.4	ns

Note: No. 1 to 12 indicate the values obtained with 1 programmed wait state. NO. 13 and 14 indicate the values obtained with 4 externally generated wait states with N = 1.

AC measurement conditions:

- Output levels: High = 0.8DVCC33 V/Low 0.2DVCC33 V, CL = 30 pF
- Input levels: High = 0.7DVCC33 V/Low 0.3DVCC33 V

W: Number of wait state cycles inserted (0 to 7 for programmed wait insertion)

N: Value of N for (3 + N) wait insertion

(1) Read cycle timing (SYSCR3<ALESEL> = 0, 1 programmed wait state)

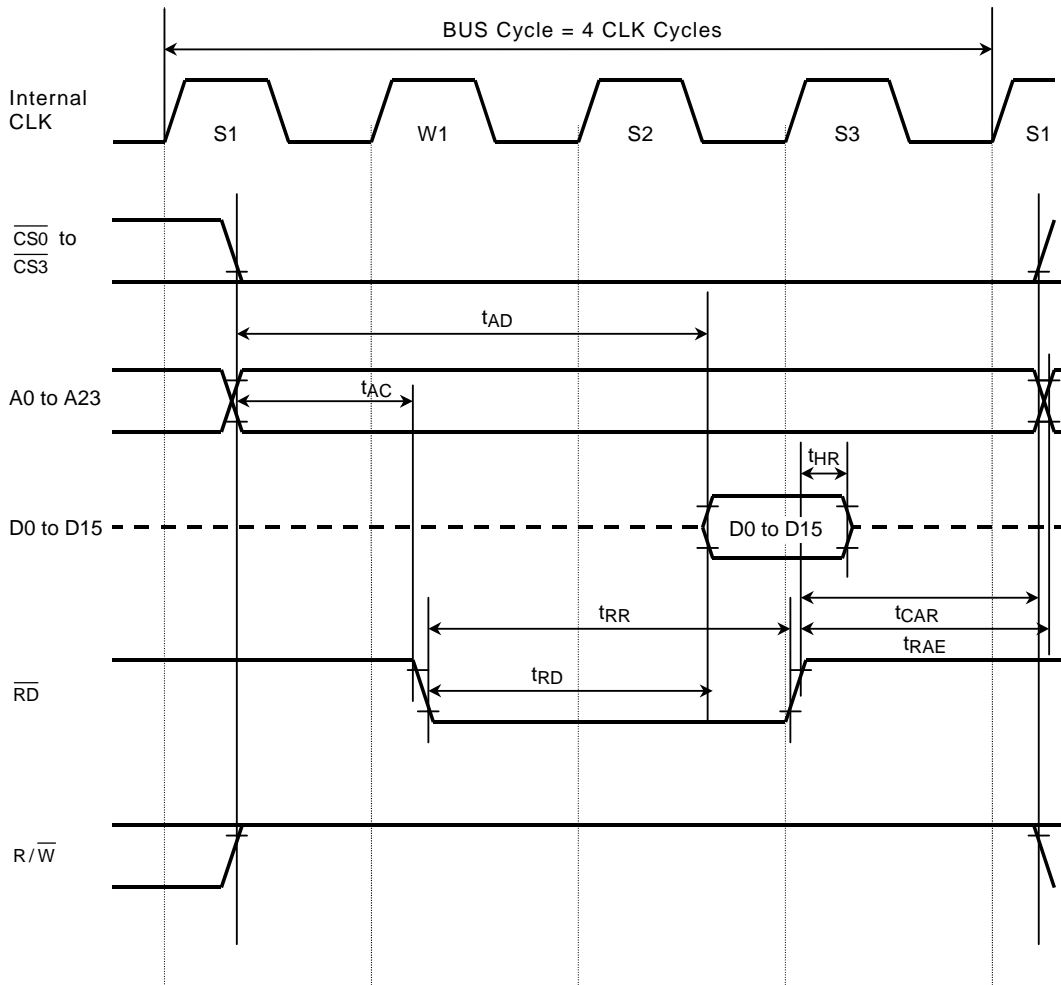

(2) Read cycle timing (SYSCR3<ALESEL> = 1, 1 programmed wait state)

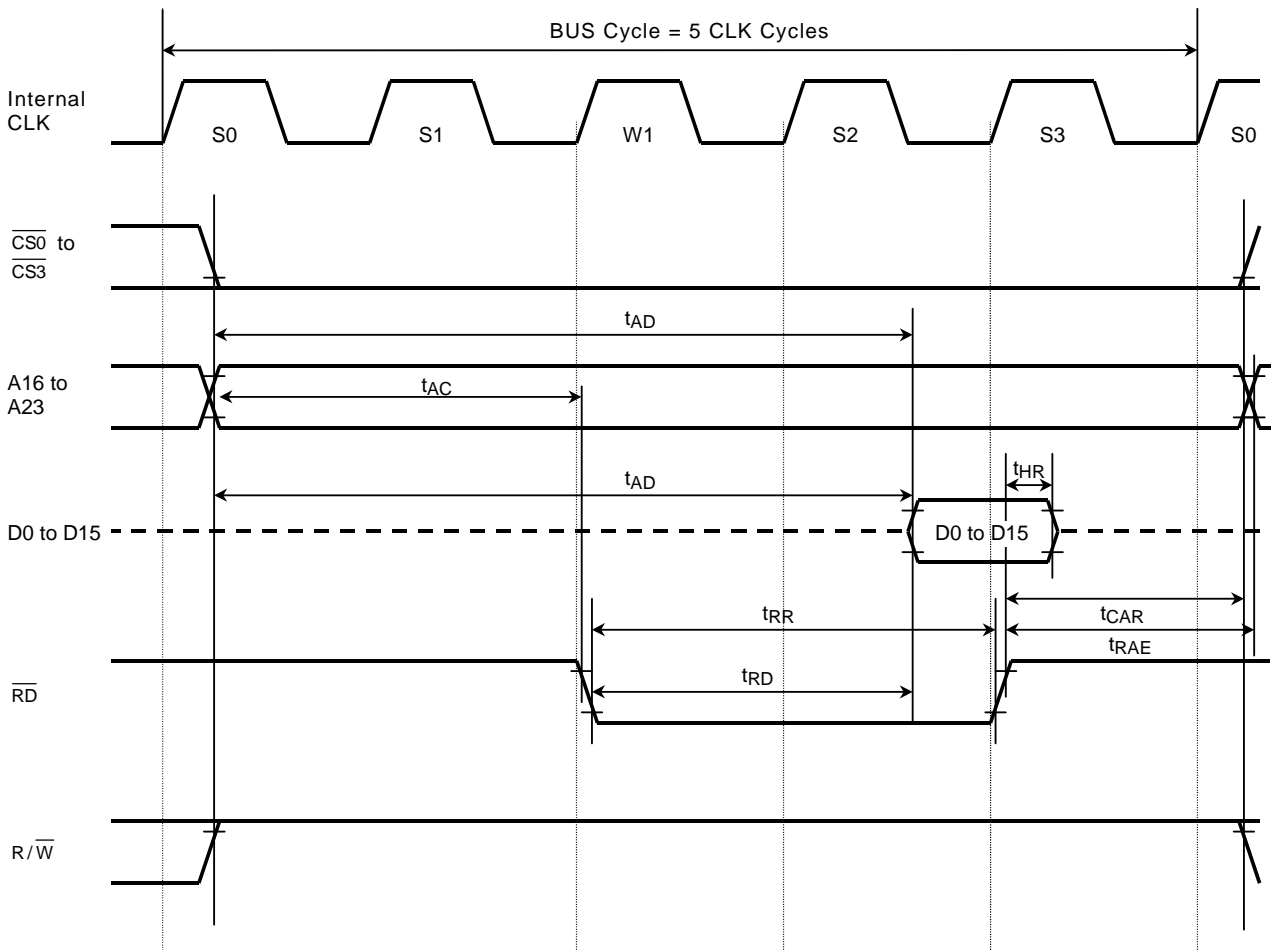

(3) Read cycle timing SYSCR3<ALESEL> = 1, 2 externally generated wait states with N = 1

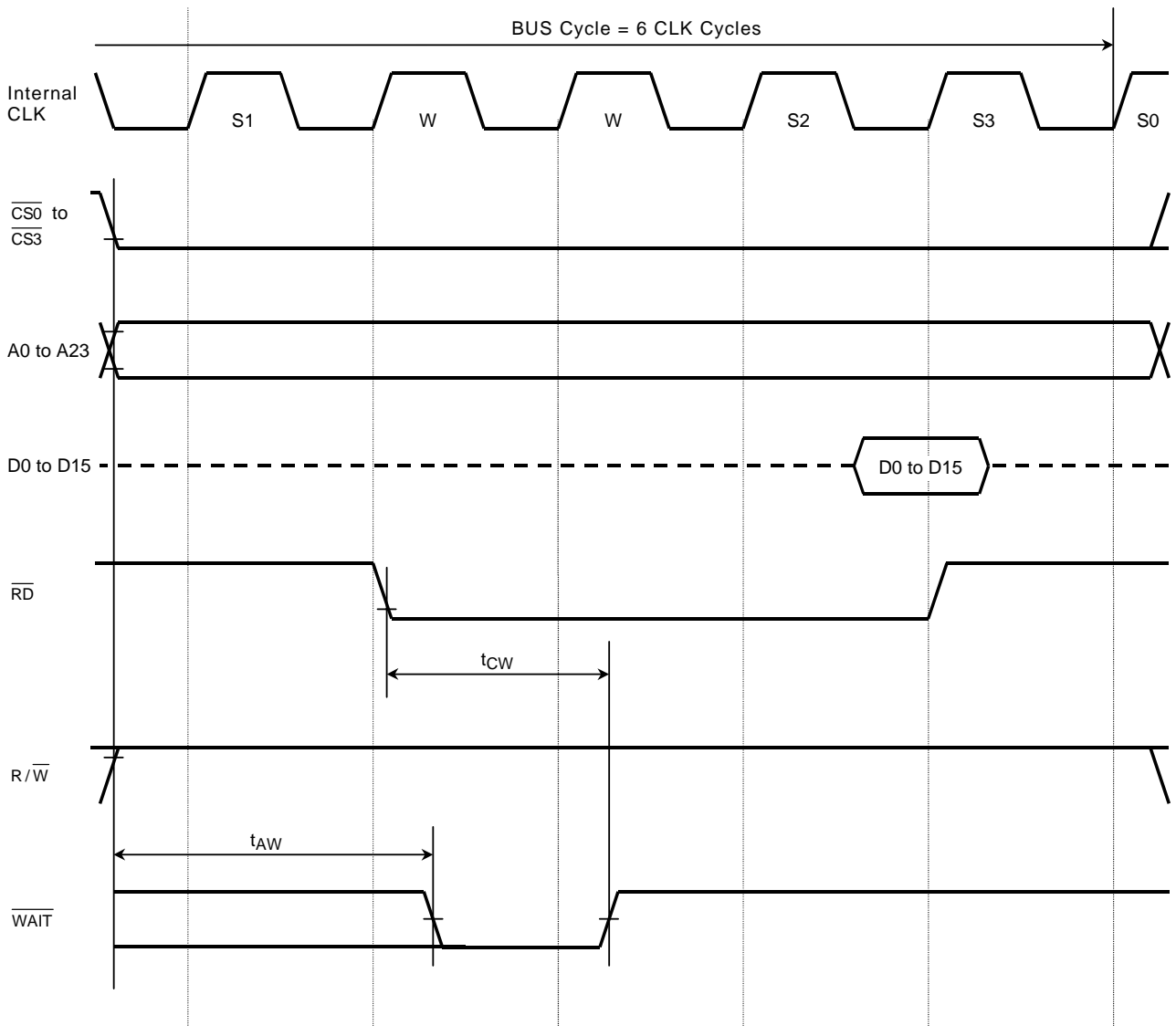

(4) Read cycle timing (SYSCR3<ALESEL> = 1, 4 externally generated wait states with N = 1)

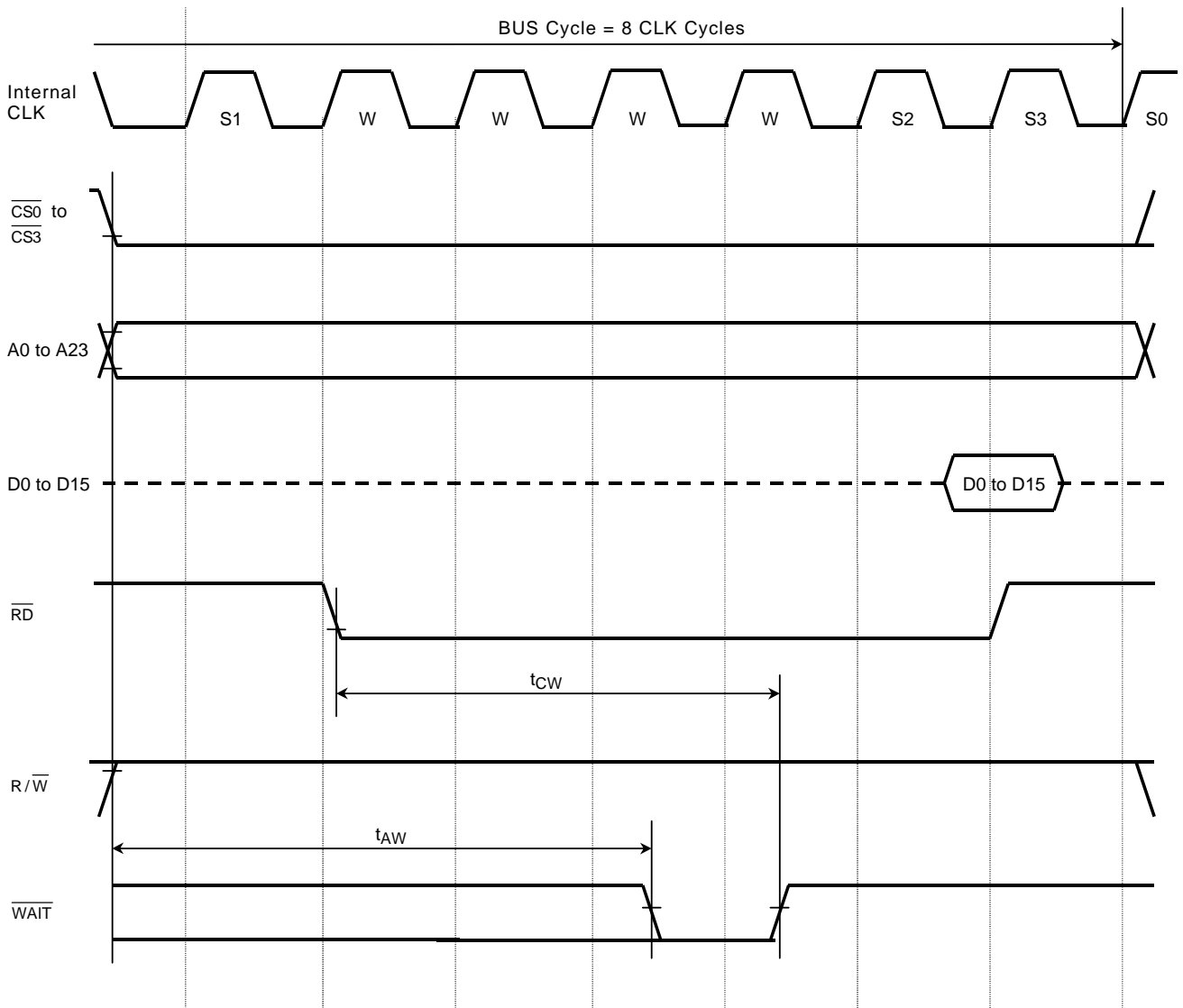

(5) Write cycle timing (SYSCR3<ALESEL> = 1, zero wait state)

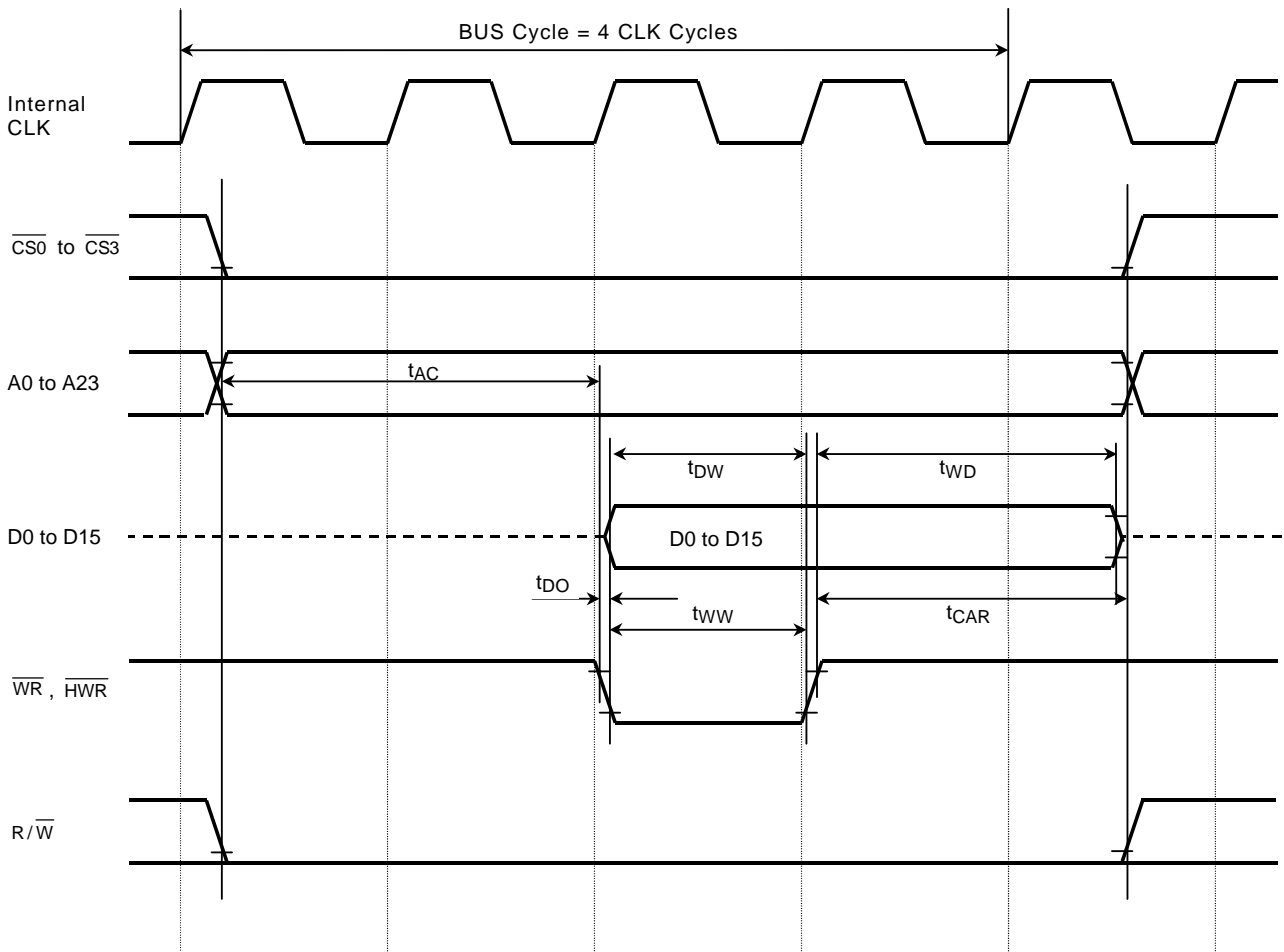

4.8 Transfer with DMA Request

The following shows an example of a transfer between the on-chip RAM and an external device in multiplex bus mode.

- 16-bit data bus width, non-recovery time
- Level data transfer mode
- Transfer size of 16 bits, device port size (DPS) of 16 bits
- Source/destination: on-chip RAM/external device

The following shows transfer operation timing of the on-chip RAM to an external bus during write operation (memory-to-memory transfer).

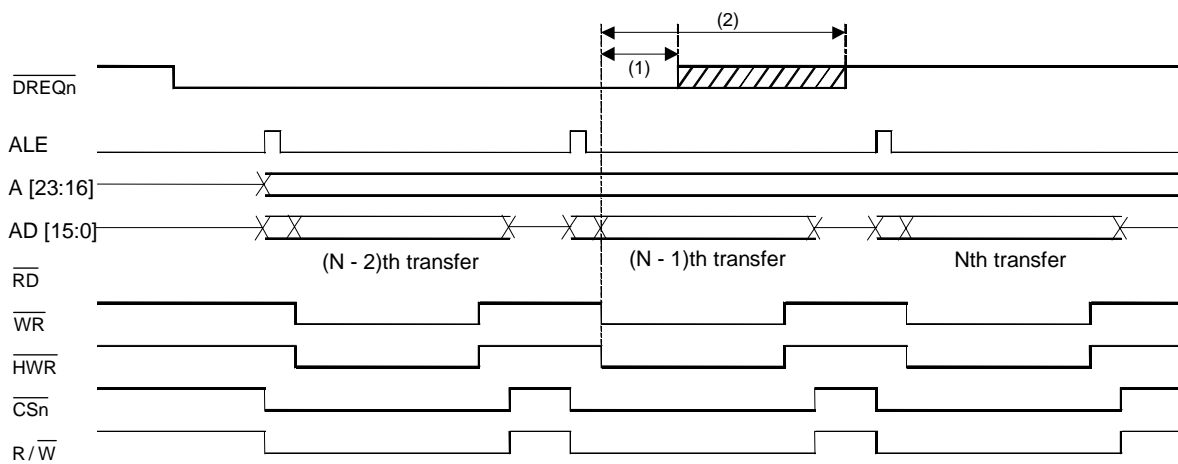

- (1) Indicates the condition under which Nth transfer is performed successfully.
- (2) Indicates the condition under which (N + 1)th transfer is not performed.

- (1) $DVCC2m = FVCC2 = CVCC2 = 2.5\text{ V} \pm 0.2\text{ V}$, $FVCC3 = 3.3\text{ V} \pm 0.3\text{ V}$, $AVCC3m = 3.3 \pm 0.2\text{ V}$,
 $DVCC33 = 2.3\text{ V to } 3.3\text{ V}$, $T_a = -20\text{ to } 85^\circ\text{C}$ ($m = 1\text{ to } 2$)

No.	Parameter	Symbol	Equation		40.5 MHz (fsys) (Note)		Unit
			(1) Min	(2) Max	Min	Max	
2	\overline{RD} asserted to \overline{DREQn} negated (external device to on-chip RAM transfer)	tDREQ_r	$Wx - 4.2$	$(2W + ALE + 6) \times - 51$	45	195	ns
3	$\overline{WR} / \overline{HWR}$ rising to \overline{DREQn} negated (on-chip RAM to external device transfer)	tDREQ_w	0	$(2W + ALE + 4) \times - 51.8$	0	145	ns

- (2) $DVCC2m = FVCC2 = CVCC2 = 2.5\text{ V} \pm 0.2\text{ V}$, $FVCC3 = 3.3\text{ V} \pm 0.3\text{ V}$, $AVCC3m = 3.3 \pm 0.2\text{ V}$,
 $DVCC33 = 1.8\text{ V} \pm 0.15\text{ V}$, $T_a = 20\text{ to } 85^\circ\text{C}$ ($m = 1\text{ to } 2$)

No.	Parameter	Symbol	Equation		40.5 MHz (fsys) (Note)		Unit
			(1) Min	(2) Max	Min	Max	
2	\overline{RD} asserted to \overline{DREQn} negated (external device to on-chip RAM transfer)	tDREQ_r	$Wx - 6.2$	$(2W + ALE + 6) \times - 56$	43	190	ns
3	$\overline{WR} / \overline{HWR}$ rising to \overline{DREQn} negated (on-chip RAM to external device transfer)	tDREQ_w	0	$(2W + ALE + 4) \times - 56.8$	0	140	ns

W: Number of wait-state cycles inserted. In the case of $(1 + N)$ externally generated wait states with $N = 1$, W becomes 2.

ALE: Apply $ALE = 0$ for ALE 0.5 clock, $ALE = 1$ for ALE 1.5 clock. The values in the above table are obtained with $W = 2$, $ALE = 0$.

4.9 Serial Channel Timing

(1) I/O Interface Mode ($DVCC3n = 3.0\text{ V} \pm 0.3\text{V}$)

In the table below, the letter x represents the f_{sys} cycle period, which varies depending on the programming of the clock gear function.

1. SCLK input mode (SIO0 to SIO6)

Parameter	Symbol	Equation		40.5 MHz		Unit
		Min	Max	Min	Max	
SCLK period	t_{SCY}	$12x$		296		ns
TxD data to SCLK rise or fall*	t_{OSS}	$2x - 45$		4		ns
TxD data hold after SCLK rise or fall*	t_{OHS}	$8x - 15$		182		ns
RxD data valid to SCLK rise or fall*	t_{SRD}	30		30		ns
RxD data hold after SCLK rise or fall*	t_{HSR}	$2x - 30$		19		ns

* SCLK rise or fall: Measured relative to the programmed active edge of SCLK.

2. SCLK output mode (SIO0 to SIO6)

Parameter	Symbol	Equation		40.5 MHz		Unit
		Min	Max	Min	Max	
SCLK period (programmable)	t_{SCY}	$8x$		197		ns
TxD data to SCLK rise	t_{OSS}	$4x - 10$		88		ns
TxD data hold after SCLK rise	t_{OHS}	$4x - 10$		88		ns
RxD data valid to SCLK rise	t_{SRD}	45		45		ns
RxD data hold after SCLK rise	t_{HSR}	0		0		ns

(2) I/O Interface Mode ($DVCC3n = 2.5\text{ V} \pm 0.2\text{ V}$)

In the table below, the letter x represents the fsys cycle period, which varies depending on the programming of the clock gear function.

1. SCLK input mode (SIO0 to SIO6)

Parameter	Symbol	Equation		40.5 MHz		Unit
		Min	Max	Min	Max	
SCLK period	t _{SCY}	16x		395		ns
TxD data to SCLK rise or fall*	t _{OSS}	4x - 60		38		ns
TxD data hold after SCLK rise or fall*	t _{OHS}	10x - 15		232		ns
RxD data valid to SCLK rise or fall*	t _{SRD}	30		30		ns
RxD data hold after SCLK rise or fall*	t _{HSR}	2x + 10		59		ns

* SCLK rise or fall: Measured relative to the programmed active edge of SCLK.

2. SCLK output mode (SIO0 to SIO6)

Parameter	Symbol	Equation		40.5 MHz		Unit
		Min	Max	Min	Max	
SCLK period (programmable)	t _{SCY}	8x		197		ns
TxD data to SCLK rise	t _{OSS}	4x - 10		88		ns
TxD data hold after SCLK rise	t _{OHS}	4x - 10		88		ns
RxD data valid to SCLK rise	t _{SRD}	60		60		ns
RxD data hold after SCLK rise	t _{HSR}	0		0		ns

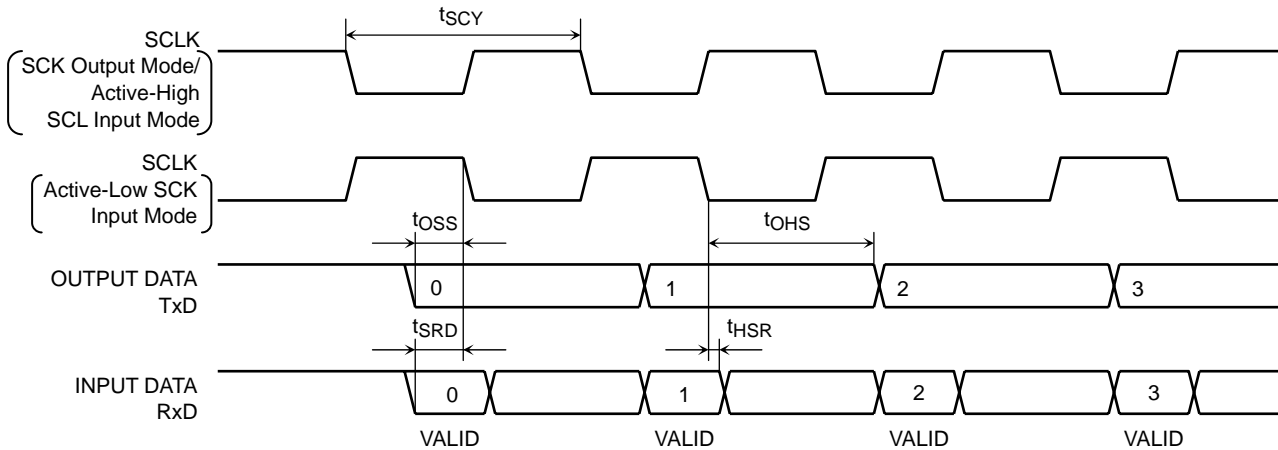

4.10 SBI Timing

(1) I2C Mode

In the table below, the letters x and T represent the f_{SYS} and ϕT_0 cycle periods, respectively. The letter n denotes the value of n programmed into the SCK[2:0] (SCL output frequency select) field in the SBI0CR1.

Parameter	Symbol	Equation		Standard Mode $f_{SYS} = 8 \text{ MHz } n = 4$		Fast Mode $f_{SYS} = 32 \text{ MHz } n = 4$		Unit
		Min	Max	Min	Max	Min	Max	
SCL clock frequency	t_{SCL}	0		0	100	0	400	kHz
Hold time for START condition	$t_{HD:STA}$			4.0		0.6		μs
SCL clock low width (Input) (Note 1)	t_{LOW}			4.7		1.3		μs
SCL clock high width (Output) (Note 2)	t_{HIGH}			4.0		0.6		μs
Setup time for a repeated START condition	$t_{SU:STA}$	(Note 5)		4.7		0.6		μs
Data hold time (Input) (Note 3, 4)	$t_{HD:DAT}$			0.0		0.0		μs
Data setup time	$t_{SU:DAT}$			250		100		ns
Setup time for STOP condition	$t_{SU:STO}$			4.0		0.6		μs
Bus free time between STOP and START conditions	t_{BUF}	(Note 5)		4.7		1.3		μs

Note 1: SCL clock low width (output) is calculated with $(2(n - 1) + 4) T$.

Standard mode: $6 \mu\text{sec}@Typ (f_{SYS} = 8 \text{ MHz}, n = 4)$

Fast mode: $1.5 \mu\text{sec}@Typ (f_{SYS} = 32 \text{ MHz}, n = 4)$

Note 2: SCL clock high width (output) is calculated with $(2(n - 1)) T$.

Standard mode: $4 \mu\text{sec}@Typ (f_{SYS} = 8 \text{ MHz}, n = 4)$

Fast mode: $1 \mu\text{sec}@Typ (f_{SYS} = 32 \text{ MHz}, n = 4)$

Note 3: The output data hold time is equal to $12x$.

Note 4: The Philips I²C-bus specification states that a device must internally provide a hold time of at least 300 ns for the SDA signal to bridge the undefined region of the fall edge of SCL. However, TMP1962F10AXBG SBI does not satisfy this requirement. Also, the output buffer for SCL does not incorporate slope control of the falling edges; therefore, the equipment manufacturer should design so that the input data hold time shown in the table is satisfied, including t_r/t_f of the SCL and SDA lines.

Note 5: Software-dependent

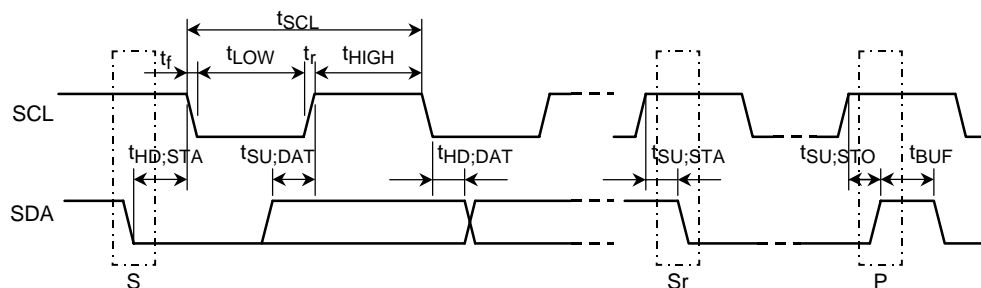

S: START condition
 Sr: Repeated START condition
 P: STOP condition

Note 6: To operate the SBI in I²C Fast mode, the f_{SYS} frequency must be no less than 20 MHz. To operate the SBI in I²C Standard mode, the f_{SYS} frequency must be no less than 4 MHz.

(2) Clock-Synchronous 8-Bit SIO Mode

In the table below, the letters x and T represent the f_{sys} and ϕT_0 cycle periods, respectively. The letter n denotes the value of n programmed into the SCK[2:0] (SCL output frequency select) field in the SBI0CR1.

The electrical specifications below are for an SCK signal with a 50% duty cycle.

1. SCK Input Mode

Parameter	Symbol	Equation		40.5 MHz		Unit
		Min	Max	Min	Max	
SCK period	t_{SCY}	16x		395		ns
SO data to SCK rise	t_{OSS}	$(t_{SCY}/2) - (6x + 30)$		19		ns
SO data hold after SCK rise	t_{OHS}	$(t_{SCY}/2) + 4x$		296		ns
SI data valid to SCK rise	t_{SRD}	0		0		ns
SI data hold after SCK rise	t_{HSR}	$4x + 10$		108		ns

2. SCK Output Mode

Parameter	Symbol	Equation		32 MHz		Unit
		Min	Max	Min	Max	
SCK period (programmable)	t_{SCY}	$2^n \cdot T$		1000		ns
SO data to SCK rise	t_{OSS}	$(t_{SCY}/2) - 20$		480		ns
SO data hold after SCK rise	t_{OHS}	$(t_{SCY}/2) - 20$		480		ns
SI data valid to SCK rise	t_{SRD}	$2x + 30$		92		ns
SI data hold after SCK rise	t_{HSR}	0		0		ns

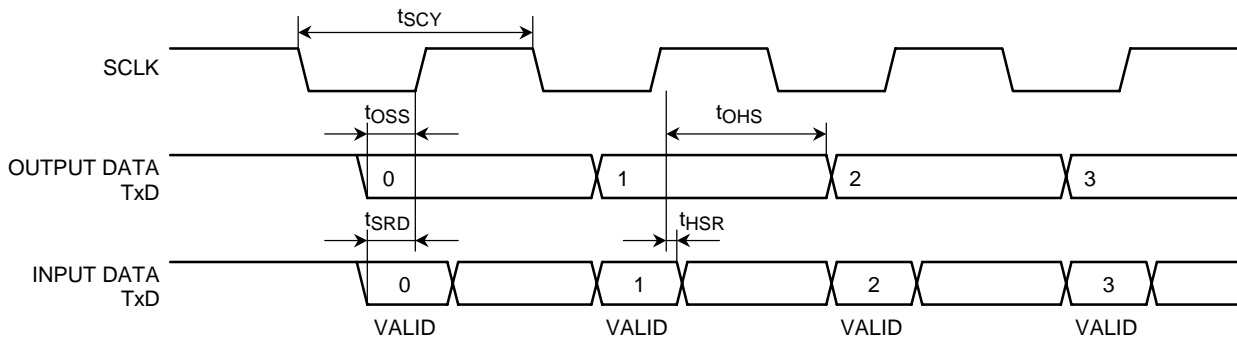

4.11 Event Counter

In the table below, the letter x represents the fsys cycle period.

Parameter	Symbol	Equation		40.5 MHz		Unit
		Min	Max	Min	Max	
Clock low pulse width	t _{VCKL}	2X + 100		149		ns
Clock high pulse width	t _{VCKH}	2X + 100		149		ns

4.12 Timer Capture

In the table below, the letter x represents the fsys cycle period.

Parameter	Symbol	Equation		40.5 MHz		Unit
		Min	Max	Min	Max	
Low pulse width	t _{CPL}	2X + 100		149		ns
High pulse width	t _{CPH}	2X + 100		149		ns

4.13 General Interrupts

In the table below, the letter x represents the fsys cycle period.

Parameter	Symbol	Equation		40.5 MHz		Unit
		Min	Max	Min	Max	
Low pulse width for INT0-INTA	t _{INTAL}	X + 100		125		ns
High pulse width for INT0-INTA	t _{INTAH}	X + 100		125		ns

4.14 $\overline{\text{NMI}}$ and STOP Wake-up Interrupts

Parameter	Symbol	Equation		40.5 MHz		Unit
		Min	Max	Min	Max	
Low pulse width for $\overline{\text{NMI}}$ and INT0-INT4	t _{INTBL}	100		100		ns
High pulse width for INT0-INT4	t _{INTBH}	100		100		ns

4.15 SCOUT Pin

Parameter	Symbol	Equation		40.5 MHz		Unit
		Min	Max	Min	Max	
Clock high pulse width	t _{SCH}	0.5T - 5		7.4		ns
Clock low pulse width	t _{SCL}	0.5T - 5		7.4		ns

Note: In the above table, the letter T represents the cycle period of the SCOUT output clock.

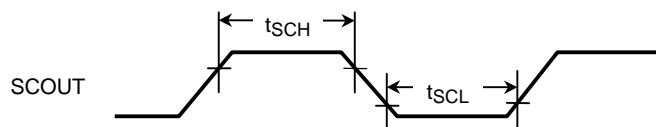

4.16 Bus Request and Bus Acknowledge Signals

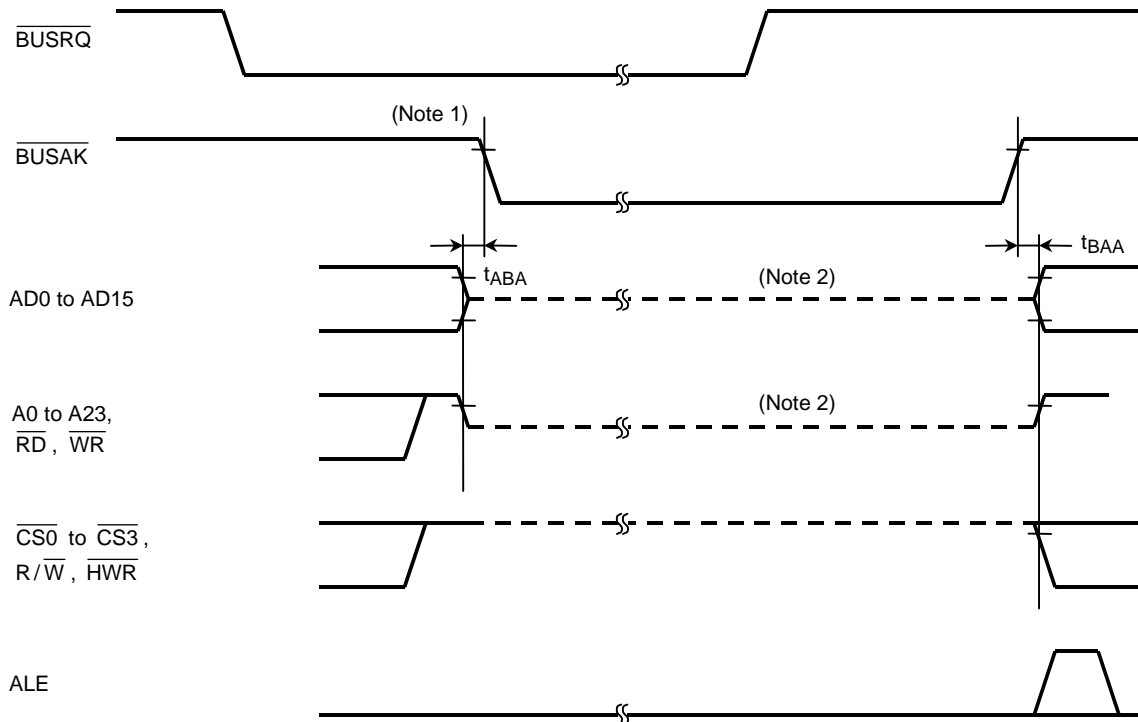

Parameter	Symbol	Equation		40.5 MHz		Unit
		Min	Max	Min	Max	
Bus float to $\overline{\text{BUSAK}}$ asserted	t_{ABA}	0	80	0	80	ns
Bus float after $\overline{\text{BUSAK}}$ negated	t_{BAA}	0	80	0	80	ns

Note 1: If the current bus cycle has not terminated due to wait-state insertion, the TMP1962F10AXBG does not respond to $\overline{\text{BUSRQ}}$ until the wait state ends.

Note 2: This broken line indicates that output buffers are disabled, not that the signals are at indeterminate states. The pin holds the last logic value present at that pin before the bus is relinquished. This is dynamically accomplished through external load capacitances. The equipment manufacturer may maintain the bus at a predefined state by means of off-chip restores, but he or she should design, considering the time (determined by the CR constant) it takes for a signal to reach a desired state. The on-chip, integrated programmable pullup/pulldown resistors remain active, depending on internal signal states.

4.17 KWUP Input

Pull-up Register Active

Parameter	Symbol	Equation		40.5 MHz		Unit
		Min	Max	Min	Max	
Low pulse width for KEY0-D	tky _{TBL}	100		100		ns
High pulse width for KEY0-D	tky _{TBH}	100		100		ns

Pull-up Register Inactive

Parameter	Symbol	Equation		40.5 MHz		Unit
		Min	Max	Min	Max	
Low pulse width for KEY0-D	tky _{TBL}	100		100		ns

4.18 Dual Pulse Input

Parameter	Symbol	Equation		40.5MHz		Unit
		Min	Max	Min	Max	
Dual input pulse period	T _{dcyc}	8Y		395		ns
Dual input pulse setup	T _{abs}	Y + 20		70		ns
Dual input pulse hold	T _{abh}	Y + 20		70		ns

Y: Sampling clock (f_{sys}/2)

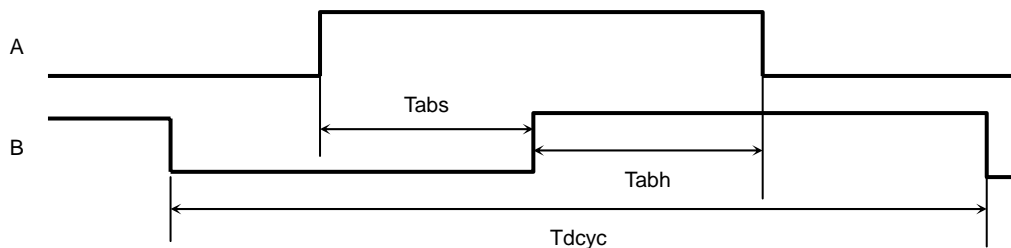

4.19 ADTRG Input

Parameter	Symbol	Equation		40.5 MHz		Unit
		Min	Max	Min	Max	
ADRG low level pulse width	tad _L	f _{sys} /2 + 20		32.4		ns
ADRG high level pulse interval	Tadh	f _{sys} /2 + 20		32.4		ns

5. Others

ESD

MM	$\pm 200V$
HBM	$\pm 1200V$

6.Package

P-FBGA281-1313-0.65B6

